

TECHNICAL SPECIFICATION

ZMGP-131LRNC



V1.1	2024-4-18				
Version	Date	Prepared Designer	Reviewed Supervisor	Approved Branch manager	Accepted

1. General

The transceiver is intended for 1310nm reach service up to 1.25Gb/s communications equipment where low-cost, extraordinary performance and reliability are essential. For different transmission distance with different optical power and sensitivity spec. The device is Class I laser safety compliant.

2. Features

- Duplex LC interface, Duplex operation
- Applicable for 10km SMF connection
- Link budget ≥ 15 dB
- Up to 1.25Gbps data rate
- Single 3.3V Power supply
- Power consumption ≤ 1 W
- Hot-Pluggable SFP footprint
- 1310nm DFB transmitter, PIN receiver
- Case Operating temperature ranges: 0°C to 85°C
- Compatible with existing CISCO, JUNIPER, and NOKIA devices

3. Applications

- Gigabit Ethernet
- Gigabit Fiber Channel
- Switched backplane applications

4. Standards

- Compliant with SFP MSA (INF-8074i)
- Compliant with SFF-8472 v12.2
- Compliant with IEEE802.3z Gigabit Ethernet
- Compliant with EN 55032:2015
- Compliant with IEC 61000-4-2
- Compliant with RoHS

5. Absolute Maximum Ratings

Parameter	Symbol	Min	Max	Unit	Notes
Storage Temperature	T_{stg}	-40	85	°C	-
Case Operating Temperature	T_C	0	85	°C	C-Temp
Relative Humidity - Storage	RH_s	5	95	%	-
Relative Humidity - Operating	RH_o	5	85	%	-
DC Supply Voltage	V_{CC}	-0.5	4.0	V	-

6. Recommended Operating Conditions

Parameter	Symbol	Min	Typ	Max	Unit	Notes
Case Operating Temperature	T_C	0	-	85	°C	-
DC Supply Voltage	V_{CC}	3.135	3.3	3.465	V	-
Module Supply Current	I_{CC}	-	-	300	mA	-
Maximum Power Dissipation	P_D	-	-	1	W	-
Data Rate	DR	-	1.25	-	Gb/s	-

7. Electrical Characteristics

Parameter	Symbol	Min	Typ	Max	Unit	Notes
TX Differential Input Amplitude	V_{IN}	250	-	1200	mVpp	-
TX Differential Input Impedence	Z_{IN}	90	-	110	Ω	-
RX Differential Output Amplitude	V_{OUT}	250	-	800	mVpp	-
RX Differential Output Impedence	Z_{OUT}	-	100	-	Ω	-
TX_fault /LOS output (TTL)	V_{OH}	2.0	-	V_{CC}	V	-
	V_{OL}	0	-	0.8	V	-
TX_disable input (TTL)	V_{IH}	2.0	-	V_{CC}	V	-
	V_{IL}	0	-	0.8	V	-

8. Transmitter Optical Characteristics

Parameter	Symbol	Min	Typ	Max	Unit	Notes
Data Rate	DR	-	1.25	-	Gbps	-
Average Optical Power	Po	-9	-	-3	dBm	1
Wavelength	λ	1270	1310	1360	nm	-
Extinction Ratio	ER	8.2	-	-	dB	-
Spectral width(@-20dB)	$\Delta\lambda$	-	-	3	nm	-
Side Mode Suppression Ratio	SMSR	30	-	-	dB	-
Pout @TX-Disable Asserted	Poff	-	-	-40	dBm	1
Eye Diagram	Complies with IEEE802.3z eye masks when filtered					

Notes :

1. Measured with a PRBS $2^{23}-1$ test pattern @1.25Gb/s.

9. Receiver Optical Characteristics

Parameter	Symbol	Min	Typ	Max	Unit	Notes
Data Rate	DR	-	1.25	-	Gbps	-
Wavelength	λ	1260	1310	1360	nm	-
Average Sensitivity	Sen	-	-	-30	dBm	1
Optical Power Overload	Psat	-3	-	-	dBm	1
LOS De-Assert	LOSD	-	-	-32	dBm	1
LOS Assert	LOSA	-38	-	-	dBm	1
LOS Hysteresis	-	0.5	-	6	dB	2

Notes :

1. Measured with a PRBS $2^{23}-1$ test pattern, @1.25Gb/s, ER=10dB, BER $\leq 10^{-12}$.
2. The LOS Hysteresis to minimize “chatter” on the output line. In principle, hysteresis alone does not guarantee chatter-free operation.

10. Typical Application Circuit

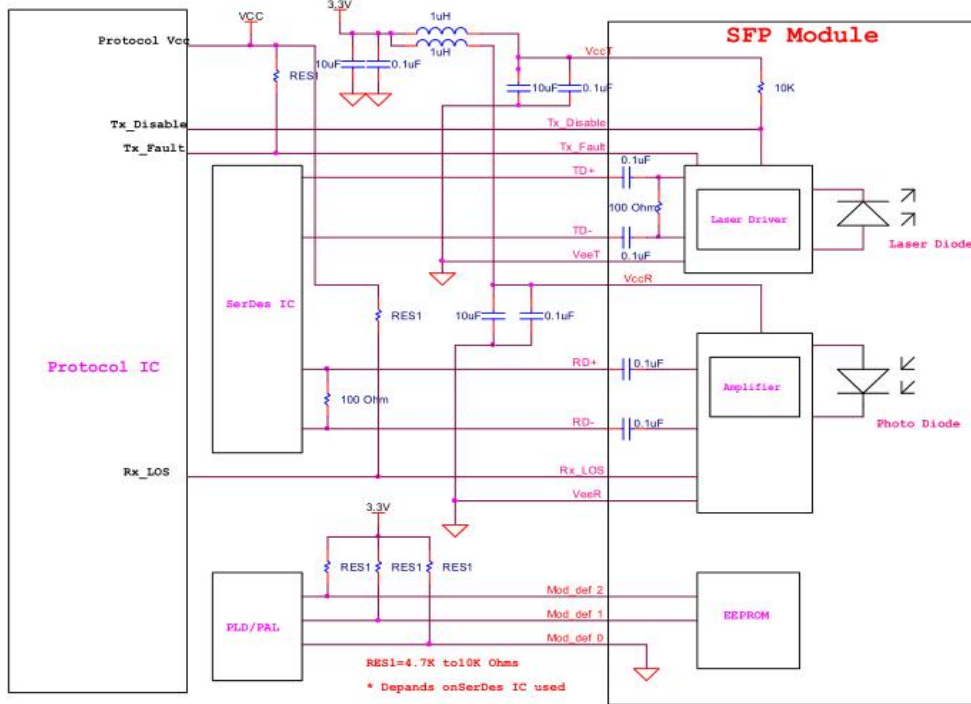

Recommended Application Interface Block Diagram

11. Pin Description

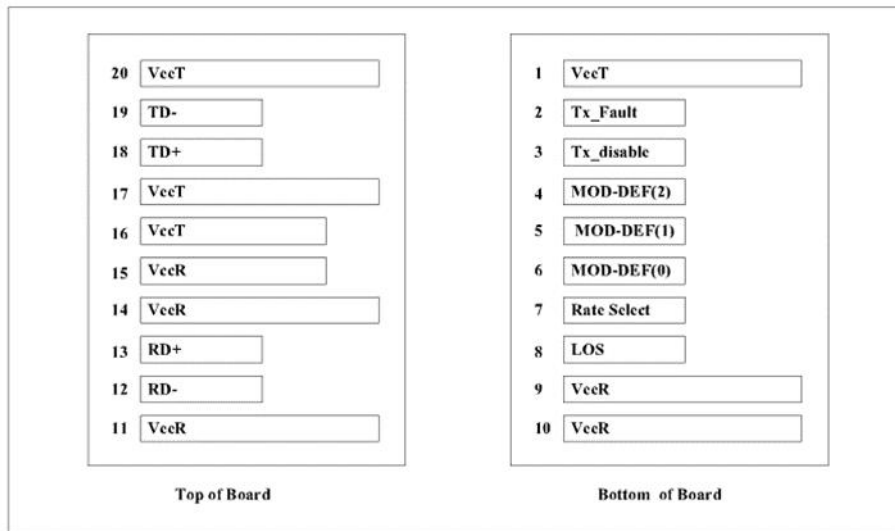

As Viewed Through Top of Board

SFP pad assignment top view

Pin	Name	Function/Description	Notes
-----	------	----------------------	-------

1	VeeT	Transmitter Ground	
2	TX Fault	Transmitter Fault Indication	1
3	TX Disable	Transmitter Disable-Module disables on high or open	2
4	MOD_DEF 2	Module Definition 2-Two wire serial ID interface	3
5	MOD_DEF 1	Module Definition 1-Two wire serial ID interface	3
6	MOD_DEF 0	Module Definition 0-Two wire serial ID interface	3
7	Rate Select	Not Connected	
8	LOS	Loss of Signal	4
9	VeeR	Receiver Ground	
10	VeeR	Receiver Ground	
11	VeeR	Receiver Ground	
12	RD-	Inverse Received Data out	5
13	RD+	Received Data out	5
14	VeeR	Receiver Ground	
15	VccR	Receiver Power — +3.3V±5%	6
16	VccT	Transmitter Power — +3.3 V±5%	6
17	VeeT	Transmitter Ground	
18	TD+	Transmitter Data In	7
19	TD-	Inverse Transmitter Data In	7
20	VeeT	Transmitter Ground	

Notes:

- The module signal grounds are isolated from the module case.
- This is an open collector/drain output that on the host board requires a 4.7KΩ to 10KΩ pull-up resistor to Vcc Host.
- This input is internally biased high with a 4.7KΩ to 10KΩ pull-up resistor to VccT.
- Two-Wire Serial interface clock and data lines require an external pull-up resistor dependent on the capacitance load.
- This is a ground return that on the host board requires a 4.7KΩ to 10KΩ pull-up resistor to VccHost.
- Rate select can also be set through the 2-wire bus in accordance with SFF-8472 v. 10.2.
Rx Rate Select is set at Bit 3, Byte 110, Address A2h. Tx Rate Select is set at Bit 3, Byte 118, Address A2h.
Writing a "1" selects maximum bandwidth operation. Rate select is the logic OR of the input state of Rate Select Pin and 2-wire bus.
- TD-/+ : These are the differential transmitter inputs. They are AC coupled differential lines with 100Ω differential termination inside the module. The AC coupling is done inside the module and is thus not required on host board.

12. Mechanical Dimensions(Unit: mm)

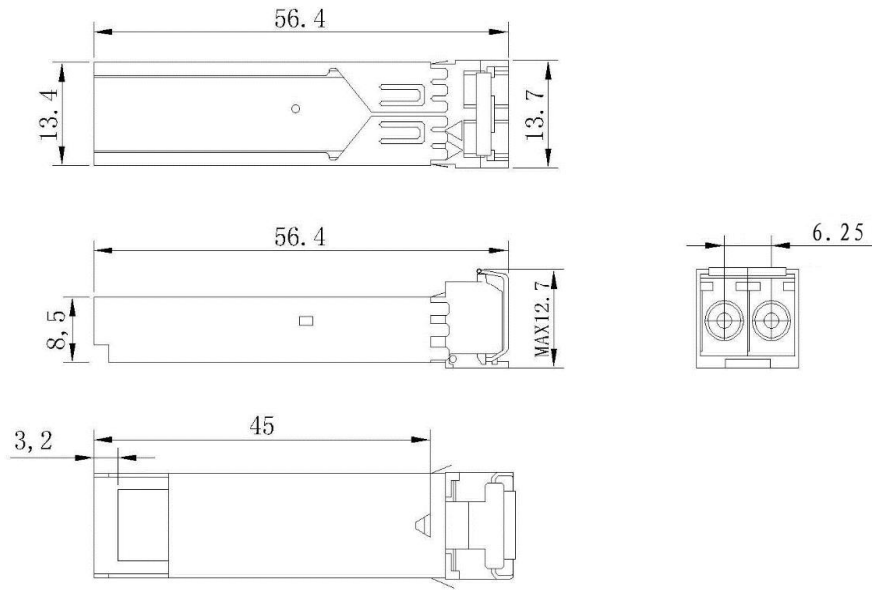

Outline Drawing

Notes:

- 1.Tolerance: +/-0.1mm.
- 2.Others are according with SFF-8074i/SFF-8432 MSA or customer SPEC.
- 3.Light port according with fiber connector SPEC.

13. Ordering Information

Part Number	Specifications						
	Pack	Rate (Gbps)	Tx (nm)	Po (dBm)	Rx	Sen (dBm)	Tc (°C)
ZMGP-131LRNC	SFP	1.25	1310	-9 ~ -3	PIN	-30	0 ~ 85

14. Revision History

Revision	Date	Change information
V1.0	2026-5-21	New Release

15. Warnings

Handling Precautions:

This device is susceptible to damage as a result of electrostatic discharge (ESD). A static free environment is highly recommended. Please follow guidelines according to proper ESD procedures.

Laser Safety:

Radiation emitted by laser devices can be dangerous to human eyes. Avoid eye exposure to direct or indirect radiation.

Notice:

The information provided on this page contains the product target specifications which are subject to change without notice. For more information ,please check with your ZTT Sales Office for product updates, changes in specifications, sample availability and products release dates.