

## ZTT GROUP

Established in 1992, ZTT started from optical fiber communications. ZTT was listed on Shanghai Stock Exchange (SSE) in 2002 (Stock Code in SSE: 600522), and issued the shares known as the "First Shares for Special Optical Fiber & Cable". Now ZTT has developed a diversified industries of telecom, power grid, marine system, renewable energy, new materials, etc.

Awarded for national innovative enterprise, Jiangsu province outstanding private enterprise, Top-500 Enterprise in China, China Quality Award, Gold-medal listed company, ZTT Group is now hosting 76 subsidiary companies and over 16,000 employees, with the deployment of Beijing Headquarters, Nantong New Headquarters, and Rudong Headquarters, as well as 54 offices and 10 marketing centers set up overseas, and 6 overseas plants operated in India, Brazil, Indonesia, Morocco, Turkey and Germany. ZTT has exported products to 160 countries and regions and has broken through the US\$10.82 billion marks in revenue in 2020.



# Helical Line Fittings





# INDEX

## Company Profile

ZTT Cable was established in 1992, and now becomes a public high-tech enterprise with 33 subsidiaries, and about 7,000 employees.

We provide products such as electrical fittings, optical fiber cable fittings, communication products, special electrical fittings and special optical fiber cable fittings, which are widely used in over 106 countries. We have excellent R&D ability and with hundreds of advanced equipments, we have capacity of manufacturing 300,000 vibration dampers, 300,000 helical formed suspension clamps, 200,000 helical formed dead-ends, and 2000 ton casting aluminum components and 10,000 ton iron components per year.

Our fittings have passed type tests in many third laboratories, such as China Electric Power Research Institute (CEPRI), Shanghai Cable Research Institute (SECRI), Kinnectrics International Inc Canada, Wuhan High-Voltage Research Institute (WHVRI) and TLC. We devote ourselves to offering safe and reliable products and quick and thoughtful service for our customers.

<b>A</b> General Introduction of Preformed Line Fittings	2
<b>B</b> Helical Fittings and Accessories for OPGW	3
Dead-end Set	3
Single Suspension Set	6
Double Suspension Set	9
Vibration Damper (4D Series)	11
Ground Wire Set	13
PTK Joint Box	14
SJD Joint Box	14
STD/STB Joint Box	15
Cable Tray (Cable Storage)	16
Downlead	16
<b>C</b> Helical Fittings and Accessories for ADSS	17
Dead-end Set	17
Single Suspension Set	19
Double Suspension Set	20
Spiral Vibration Damper	21
Corona Coil	22
Downlead	22
Tray and Joint Box	22
Fastened Fittings	23
<b>D</b> Helical Fittings and Accessories for OPPC	24
Dead-end Set	24
Catalogue Table of Dead-end for large strength OPPC	25
Suspension Set	26
Cable Tray	27
Joint Box	27
Vibration Damper	27
<b>E</b> Helical Fittings and Accessories for Conductor	28
Dead-end Clamp	28
Preformed Armor-Grip Suspension Clamp	29
Matching Fittings of Double Suspension Set	31
Armor Rods, Repair Rods and Helical Splices	32
Armor Rods and Repair rods	33
Helical Splices	34
Helical Full Tension Splices	35
Preformed Vibration Damper Series	37
Rubber type preformed vibration damper	37
Hook type preformed vibration damper (Symmetrical) for conductor	38
Hook type preformed vibration damper (asymmetrical) for conductor and ground wire	38
Armor-grip Spacer Damper	39
Armor-grip Twin Spacer Damper	40
Armor-grip Quad Spacer Damper	40
Armor-grip Quad Spacer Damper	40
<b>F</b> Reference	41



# General Introduction of Preformed Line Fittings

The traditional suspension clamps and tension clamps are fixed with ways by bolts and compression. However the OPGW, ADSS and OPPC can not be installed by these two traditional ways, for there are optical units in their structure. Therefore the preformed fittings are developed to solve this problem.

Preformed fittings have a lot of advantaged compared to traditional fittings. They are easily installed, have large contact area with cables which provide uniform distribution power, good anti-fatigue performance, tiny harm to cables and so on. Based on these characteristics, the preformed fittings are used more and more on overhead optical and power cables.

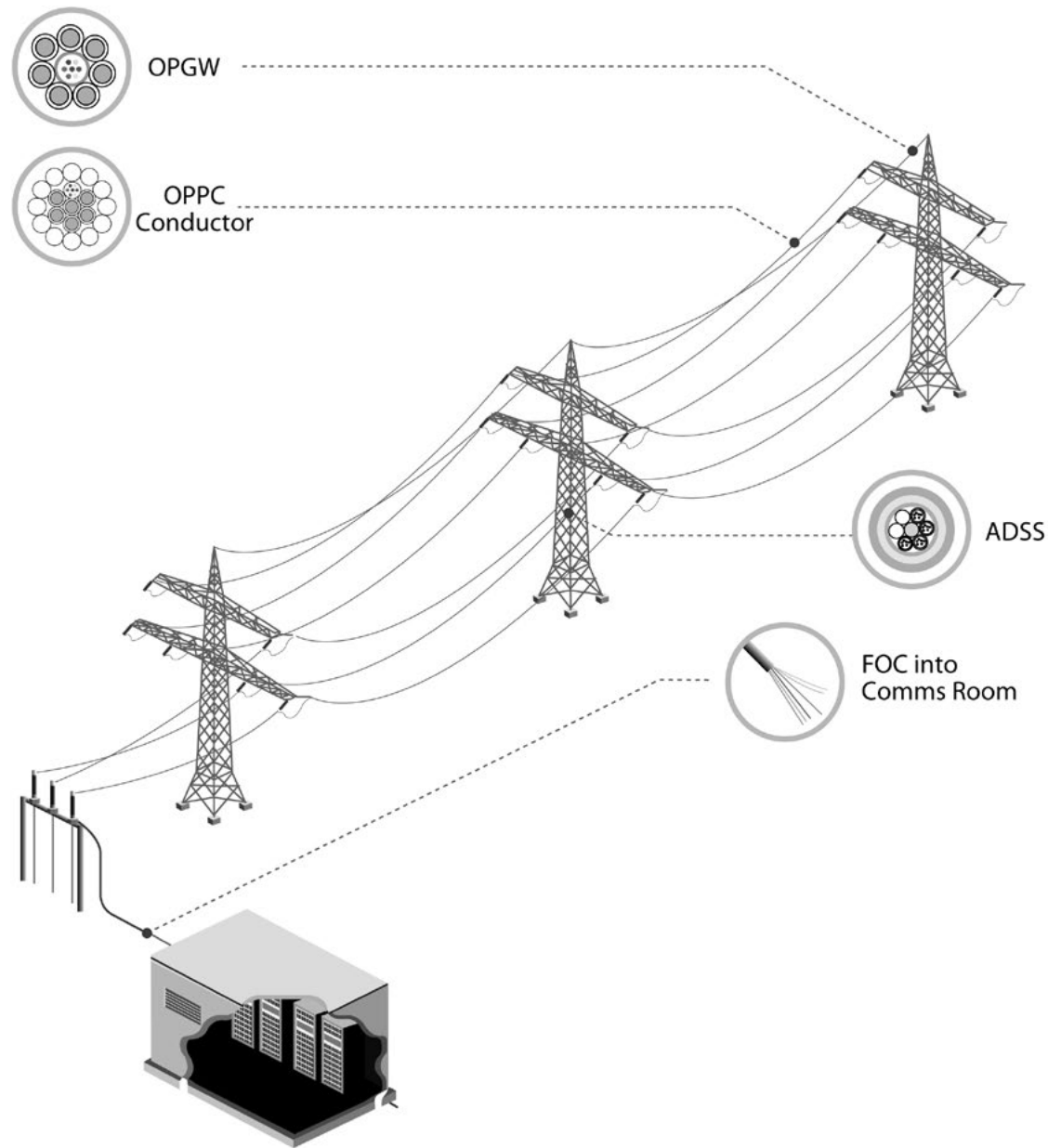

The location of OPGW, OPPC(Conductor) and ADSS

# Helical Fittings and Accessories for OPGW

## Dead-end for OPGW

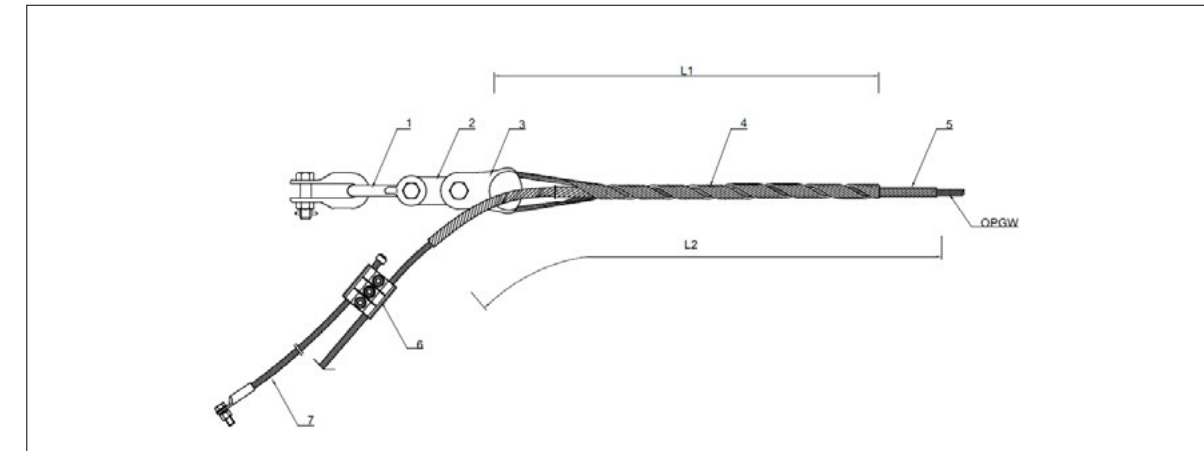

- 1. U shackle: Galvanized steel
- 2. PD Link: Galvanized steel
- 3. Thimble clevis: Galvanized steel
- 4. Dead-end component: Aluminum-clad steel
- 5. Structural reinforcing rods: Aluminum-clad steel
- 6. Parallel groove clamp: Aluminum alloy
- 7. Grounding wire set: Aluminum

### Product Characteristic

- The helical formed wire inner and dead-end components are designed to transfer axial tensile loads and distribute radial compressive forces over the surface in contact with the OPGW to minimize effects on the central core and internal optical fibers.
- The inside of inner and outer rods covered with silicon carbide, increasing damping effects.
- Minimum holding strength of dead-end set not less than 95% RTS of cable.
- Excellent anti-fatigue characteristic.
- The installation is convenient, no special tools needed.

### Consideration

- Once installed, structural reinforcing rods and dead-end component may be removed and reinstalled once for repositioning purpose. Do not reuse after this initial installation. The hardware components may be reused as long as they are in good condition. Do not modify any components.
- Right-hand lay is standard. Left-hand lay is available.
- Contact us in advance for the requirement of left-hand lay dead-end clamp.
- U shackle, Ball eye and other hardware accessories may be ordered with the dead-end.
- The fittings can only be installed by experienced workers.

Table A-1. Dead-end for OPGW

ZTT Cat-No.	Dia. Range		95% RTS (kN)	Structural reinforcing rods				Dead-end component				Thimble		
	Min (mm)	Max (mm)		L1 (mm)	Dia. (mm)	Rods no.	Weight (kg)	L2 (mm)	Dia. (mm)	Rods no.	Weight (kg)	ZTT Cat-No.	UTS (kN)	Weight (kg)
ON-070-089	8.0	8.9	≤70	1400	2.5	11	0.54	1060	3.5	6	0.89	TC-7	70	0.96
ON-080-094	9.0	9.4	≤70	1400	2.5	12	0.59	1060	3.5	6	0.89	TC-7	70	0.96
ON-080-104	9.5	10.4	≤80	1500	2.5	13	0.68	1160	3.5	6	0.97	TC-12	120	1.4

ZTT Cat-No.	Dia. Range		95% RTS (kN)	Structural reinforcing rods				Dead-end component				Thimble		
	Min mm	Max mm		L1 (mm)	Dia. (mm)	Rods no.	Weight (kg)	L2 (mm)	Dia. (mm)	Rods no.	Weight (kg)	ZTT Cat- No.	UTS (kN)	Weight (kg)
ON-080-111	10.5	11.1	≤80	1500	2.5	14	0.74	1160	3.5	6	0.97	TC-12	120	1.4
ON-080-115	11.2	11.5	≤80	1500	2.5	14	0.74	1160	3.5	7	1.16	TC-12	120	1.4
ON-080-124	11.6	12.4	≤80	1500	2.5	15	0.79	1170	3.5	7	1.17	TC-12	120	1.4
ON-080-134	12.5	13.4	≤80	1600	2.5	16	0.90	1270	3.5	7	1.27	TC-12	120	1.4
ON-080-149	13.5	14.9	≤80	1600	2.5	17	0.95	1270	3.5	7	1.27	TC-12	120	1.4
ON-080-159	15.0	15.9	≤80	1600	2.5	17	0.95	1280	3.5	7	1.28	TC-12	120	1.4
ON-080-169	16.0	16.9	≤80	1700	2.5	18	1.07	1380	3.5	7	1.38	TC-12	120	1.4
ON-080-179	17.0	17.9	≤80	1700	2.5	19	1.13	1380	3.5	7	1.40	TC-12	120	1.4
ON-080-189	18.0	18.9	≤80	1800	3.0	18	1.46	1490	4.0	7	1.9	TC-12	120	1.4
ON-080-199	19.0	19.9	≤80	1800	3.0	19	1.54	1490	4.0	7	1.90	TC-12	120	1.4
ON-100-210	20.0	21.0	≤80	1900	3.0	20	1.71	1600	4.0	7	2.00	TC-12	120	1.4
ON-100-124	11.6	12.4	81-100	1600	2.5	15	0.84	1270	4.0	6	1.38	TC-12	120	1.4
ON-100-134	12.5	13.4	81-100	1700	2.5	16	0.95	1370	4.0	7	1.79	TC-12	120	1.4
ON-100-149	13.5	14.9	81-100	1800	2.5	17	1.07	1470	4.0	7	1.89	TC-12	120	1.4
ON-100-159	15.0	15.9	81-100	1800	2.5	17	1.07	1480	4.0	7	1.90	TC-12	120	1.4
ON-100-169	16.0	16.9	81-100	1900	2.5	18	1.20	1580	4.0	7	2.00	TC-12	120	1.4
ON-100-179	17.0	17.9	81-100	1900	2.5	19	1.26	1580	4.0	7	2.00	TC-12	120	1.4
ON-100-189	18.0	18.9	81-100	2000	3.0	18	1.70	1690	4.0	7	2.10	TC-12	120	1.4
ON-100-199	19.0	19.9	81-100	2000	3.0	19	1.71	1690	4.0	7	2.10	TC-12	120	1.4
ON-130-210	20.0	21.0	81-100	2100	3.0	20	1.89	1800	4.0	7	2.20	TC-12	120	1.4
ON-130-124	11.6	12.4	101-130	1900	2.5	15	1.00	1570	4.0	6	2.09	TC-16	160	2.3
ON-130-134	12.5	13.4	101-130	2000	2.5	16	1.12	1670	4.8	6	2.61	TC-16	160	2.3
ON-130-149	13.5	14.9	101-130	2000	2.5	17	1.19	1680	4.8	6	2.63	TC-16	160	2.3
ON-130-159	15.0	15.9	101-130	2000	2.5	17	1.19	1680	4.8	7	3.15	TC-16	160	2.3
ON-130-169	16.0	16.9	101-130	2100	2.5	18	1.32	1780	4.8	7	3.25	TC-16	160	2.3
ON-130-179	17.0	17.9	101-130	2100	2.5	19	1.40	1790	4.8	7	3.30	TC-16	160	2.3
ON-130-189	18.0	18.9	101-130	2200	3.0	18	1.78	1890	4.8	7	3.50	TC-16	160	2.3
ON-130-199	19.0	19.9	101-130	2200	3.0	19	1.88	1890	4.8	7	3.50	TC-16	160	2.3
ON-150-210	20.0	21.0	101-130	2300	3.0	20	2.07	2000	4.8	7	3.70	TC-16	160	2.3
ON-150-149	13.5	14.9	130-150	2100	2.5	17	1.25	1780	4.8	6	2.93	TC-16	160	2.3
ON-150-159	15.0	15.9	131-150	2100	2.5	17	1.25	1780	4.8	7	3.35	TC-16	160	2.3
ON-150-169	16.0	16.9	131-150	2200	2.5	18	1.32	1880	4.8	7	3.55	TC-16	160	2.3
ON-150-179	17.0	17.9	131-150	2200	2.5	19	1.46	1880	4.8	7	3.40	TC-16	160	2.3
ON-150-189	18.0	18.9	131-150	2300	3.0	18	1.86	1990	4.8	7	3.70	TC-16	160	2.3
ON-150-199	19.0	19.9	131-150	2400	3.0	19	2.10	2090	4.8	7	3.80	TC-16	160	2.3
ON-180-210	20.0	21.0	131-150	2500	3.0	20	2.25	2200	4.8	7	4.00	TC-16	160	2.3
ON-180-189	18.0	18.9	151-180	2500	3.0	18	2.03	2190	5.2	7	4.90	TCB-58/70 +PS-21N	210	4.84
ON-180-199	19.0	19.9	151-180	2600	3.0	19	2.31	2290	5.2	7	5.10	TCB-58/70 +PS-21N	210	4.84
ON-180-210	20.0	21.0	151-180	2700	3.0	20	2.43	2400	5.2	7	5.40	TCB-58/70 +PS-21N	210	4.84

Table A-2. Dead-end for OPGW (high tension strength)

Catalogue Number	Suitable Strength(kN)	Inner rods (mm)		Middle rods (mm)		Outer rods (mm)	
		Dia.	Length	Dia.	Length	Dia.	Length
ON-AAA-****	201~250	3.0	2200	4.0	1800	4.0	1500
ON-AAA-****	251~350	3.0	2500	4.8	2200	4.8	2000
ON-AAA-****	351~500	3.0	3000	5.2	2500	5.2	2200

Note: AAA- is 95% RTS of OPGW.

\*\*\*\*- is on behalf of OPGW diameter, e.g. 1350 indicates the diameter of OPGW is 13.50mm Dia.

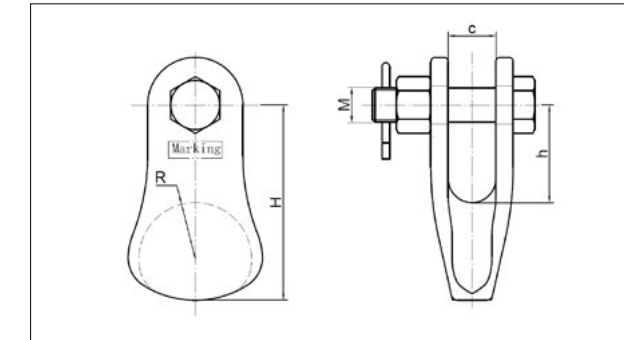
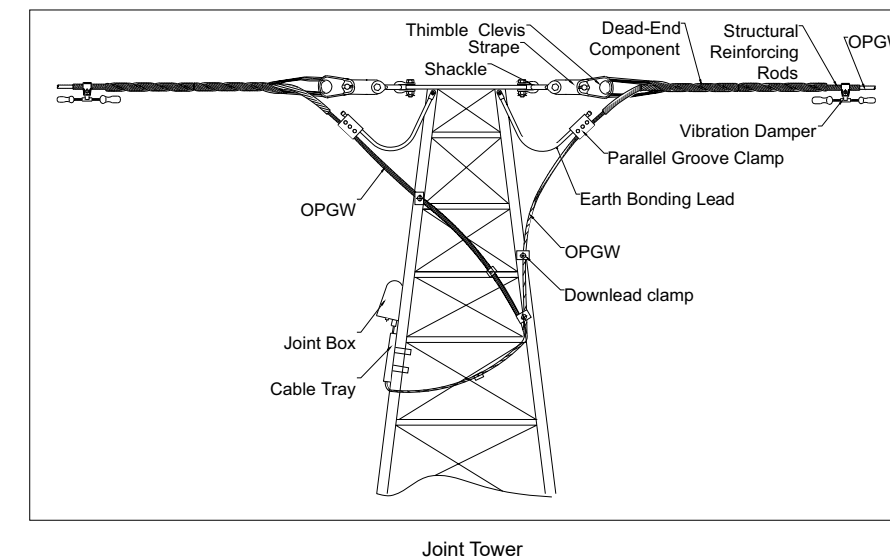

Table A-3. Thimble clevis for Dead-end for OPGW

Catalogue Number	UTS (kN)	Dimension (mm)					Wight (kg)
		C	h	H	R	M	
TC-7	70	22	45	90	26	M16	0.96
TC-12	120	24	47	97	30	M18	1.50
TC-16	160	26	55	115	35	M24	2.30

Note: For other requirements or more information, please consult ZTT.

Installation Diagram on Tower



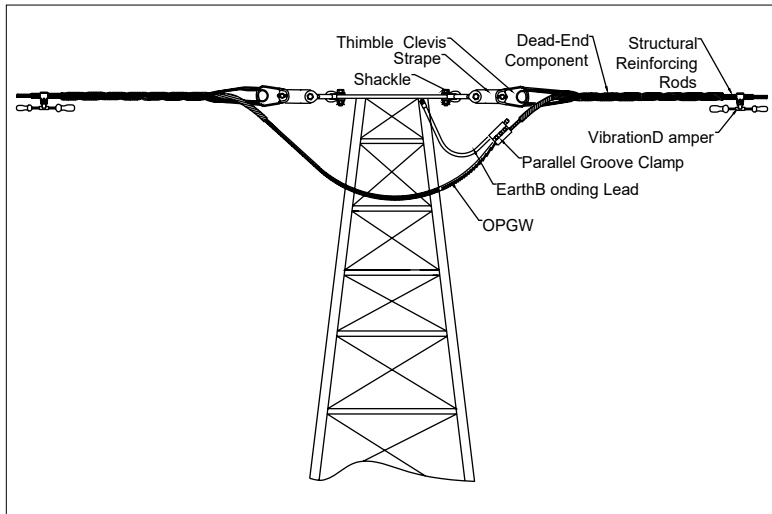

Pass Tower

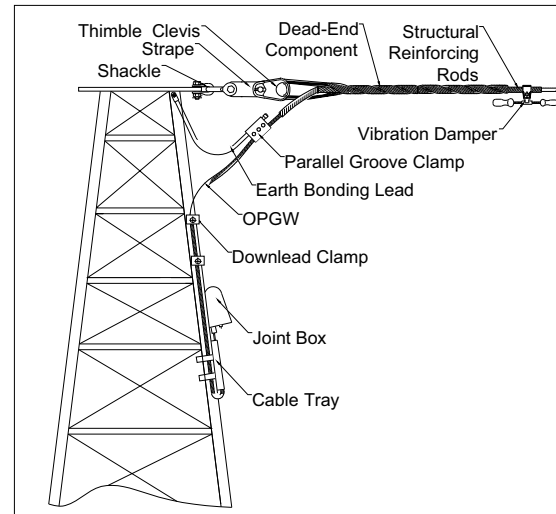

Terminal Tower

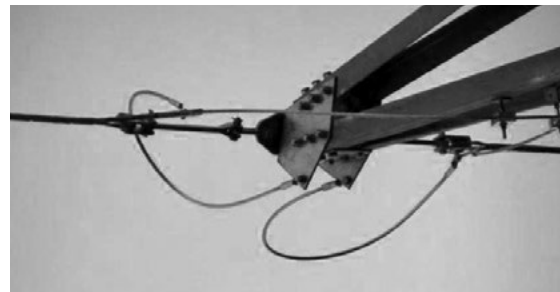

Joint tower

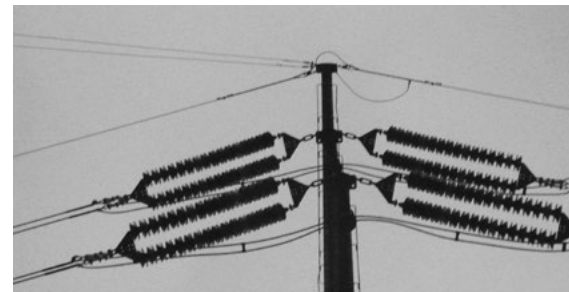

Pass pole

### Single Suspension Set for OPGW

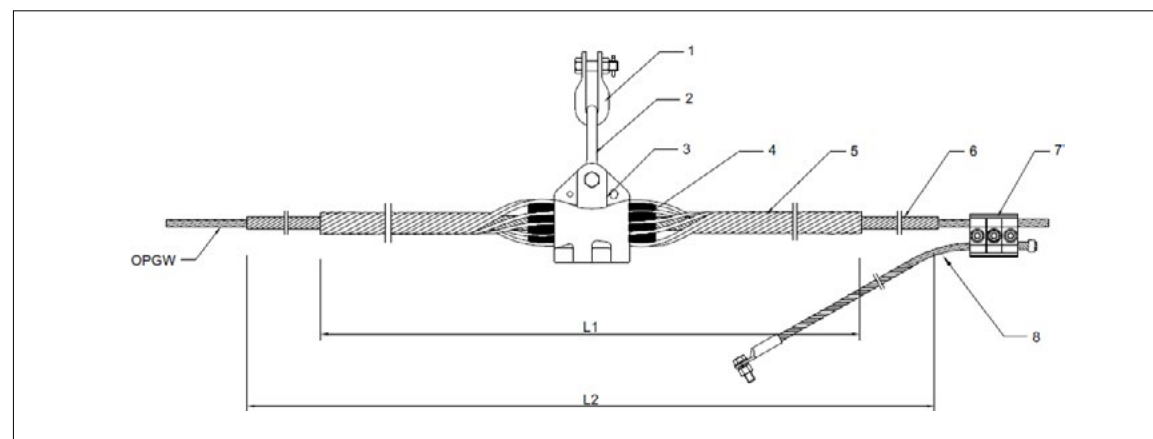

- |                                |   |
|--------------------------------|---|
| 1. U shackle: Galvanized steel | 5. Outer rods: High strength aluminum alloy         |
| 2. Eye link: Galvanized steel  | 6. Structural reinforcing rods: Aluminum-clad steel |
| 3. Clamp body: Aluminum alloy  | 7. Parallel groove clamp: Aluminum alloy            |
| 4. Insert: EPDM                | 8. Ground wire set: Aluminum                        |

Note: 1. The shapes for both no. 3 clamp body and no. 7 parallel groove clamp are determined by OPGW's diameter, which in the above drawing are just for reference.

2. For other requirements or more information, please consult ZTT.

### Product Characteristic

- The suspension set provides superior cable and fiber protection at the support point. The combination of structural reinforcing rods, outer rods, clamp body and resilient Insert reduces compression, clamping and bending stresses on cable. Negative weather-related cable motion, such as Aeolian vibration, galloping, and wind sway are also minimized.
- The insert for resistance to ozone attack, weathering, extreme high and low temperature variations. An aluminum alloy reinforcement is molded into the elastomer.
- The slip load of suspension set can reach approximate 14-20% of OPGW rated strength to offer sufficient holding strength for OPGW.

### Consideration

- The maximum recommended line angle for a single suspension set is 30°. Double one is recommended for OPGW line angle between 30° and 60°.
- The standard products are suitable for Right-hand lay OPGW (outer layer). If the outer layer of OPGW is Left-hand lay, please specify.
- Once installed, do not reuse the rod components. The hardware components may be reused as desired as long as they are in good condition. Do not modify any components.

Table B-1 Single Suspension set for OPGW

Catalogue number	Dia. Range		Structural reinforcing rods				Outer rods				RTS (kN)	Clamp body
	Min mm	Max mm	L2 (mm)	Dia. (mm)	Rods no.	Weight (kg)	L1 (mm)	Dia. (mm)	Rods no.	Weight (kg)		
OC-0200-089	8.0	8.9	1600	3.0	11	0.8	1000	6.0	9	0.7	≤40	TK-10
OC-0200-099	9.0	9.9	1600	3.0	12	0.9	1000	6.0	10	0.8	≤40	TK-10
OC-0200-109	10.0	10.9	1600	3.0	12	0.9	1000	6.0	10	0.8	≤40	TK-10
OC-0200-119	11.0	11.9	1600	3.0	13	1.0	1000	6.0	10	0.8	≤40	TK-10
OC-0200-123	12.0	12.3	1600	3.0	14	1.1	1000	6.0	10	0.8	≤40	TK-10
OC-0200-135	12.4	13.5	1600	3.0	14	1.1	1000	6.0	11	0.9	≤40	TK-10
OC-0200-148	13.6	14.8	1600	3.0	15	1.2	1000	6.0	11	0.9	≤40	TK-10
OC-0200-158	14.9	15.8	1600	3.0	16	1.3	1000	6.0	12	1.0	≤40	TK-10
OC-0200-169	15.9	16.9	1600	3.0	17	1.4	1000	6.0	12	1.0	≤40	TK-10
OC-0200-180	17.0	18.0	1600	3.0	18	1.5	1000	6.3	12	1.1	≤40	TK-12-2
OC-0300-089	8.0	8.9	1800	3.0	11	0.9	1200	6.0	9	0.8	41-50	TK-10
OC-0300-099	9.0	9.9	1800	3.0	12	1.0	1200	6.0	10	0.9	41-50	TK-10
OC-0300-109	10.0	10.9	1800	3.0	12	1.0	1200	6.0	10	0.9	41-50	TK-10
OC-0300-119	11.0	11.9	1800	3.0	13	1.1	1200	6.0	10	0.9	41-50	TK-10
OC-0300-123	12.0	12.3	1800	3.0	14	1.2	1200	6.0	10	0.9	41-50	TK-10
OC-0300-135	12.4	13.5	1800	3.0	14	1.2	1200	6.0	11	1.0	41-50	TK-10
OC-0300-148	13.6	14.8	1800	3.0	15	1.3	1200	6.0	11	1.0	41-50	TK-10
OC-0300-158	14.9	15.8	1800	3.0	16	1.4	1200	6.0	12	1.1	41-50	TK-10
OC-0300-169	15.9	16.9	1800	3.0	17	1.5	1200	6.0	12	1.1	41-50	TK-10
OC-0300-180	17.0	18.0	1800	3.0	18	1.6	1200	6.3	12	1.3	41-50	TK-12-2
OC-0400-089	8.0	8.9	1900	3.0	11	1.0	1300	6.0	9	0.9	51-60	TK-10
OC-0400-099	9.0	9.9	1900	3.0	12	1.1	1300	6.0	10	1.0	51-60	TK-10
OC-0400-109	10.0	10.9	1900	3.0	12	1.1	1300	6.0	10	1.0	51-60	TK-10
OC-0400-119	11.0	11.9	1900	3.0	13	1.2	1300	6.0	10	1.0	51-60	TK-10
OC-0400-123	12.0	12.3	1900	3.0	14	1.3	1300	6.0	10	1.0	51-60	TK-10
OC-0400-135	12.4	13.5	1900	3.0	14	1.3	1300	6.0	11	1.1	51-60	TK-10
OC-0400-148	13.6	14.8	1900	3.0	15	1.4	1300	6.0	11	1.1	51-60	TK-10
OC-0400-158	14.9	15.8	1900	3.0	16	1.5	1300	6.0	12	1.2	51-60	TK-10
OC-0400-169	15.9	16.9	1900	3.0	17	1.6	1300	6.0	12	1.2	51-60	TK-10
OC-0400-180	17.0	18.0	1900	3.0	18	1.7	1300	6.3	12	1.4	51-60	TK-12-2
OC-0500-089	8.0	8.9	2000	3.0	11	1.1	1400	6.0	9	1.0	61-70	TK-10
OC-0500-099	9.0	9.9	2000	3.0	12	1.1	1400	6.0	10	1.1	61-70	TK-10
OC-0500-109	10.0	10.9	2000	3.0	12	1.1	1400	6.0	10	1.1	61-70	TK-10
OC-0500-119	11.0	11.9	2000	3.0	13	1.2	1400	6.0	10	1.1	61-70	TK-10

Catalogue number	Dia. Range		Structural reinforcing rods				Outer rods				RTS (kN)	Clamp body
	Min mm	Max mm	L2 (mm)	Dia. (mm)	Rods no.	Weight (kg)	L1 (mm)	Dia. (mm)	Rods no.	Weight (kg)		
OC-0500-123	12.0	12.3	2000	3.0	14	1.3	1400	6.0	10	1.1	61-70	TK-10
OC-0500-135	12.4	13.5	2000	3.0	14	1.3	1400	6.0	11	1.2	61-70	TK-10
OC-0500-148	13.6	14.8	2000	3.0	15	1.4	1400	6.0	11	1.2	61-70	TK-10
OC-0500-158	14.9	15.8	2000	3.0	16	1.6	1400	6.0	12	1.3	61-70	TK-10
OC-0500-169	15.9	16.9	2000	3.0	17	1.7	1400	6.0	12	1.3	61-70	TK-10
OC-0500-180	17.0	18.0	2000	3.0	18	1.8	1400	6.3	12	1.5	61-70	TK-12-2
OC-0600-089	8.0	8.9	2100	3.0	11	1.1	1500	6.0	9	1.0	71-80	TK-10
OC-0600-099	9.0	9.9	2100	3.0	12	1.2	1500	6.0	10	1.1	71-80	TK-10
OC-0600-109	10.0	10.9	2100	3.0	12	1.2	1500	6.0	10	1.1	71-80	TK-10
OC-0600-119	11.0	11.9	2100	3.0	13	1.3	1500	6.0	10	1.1	71-80	TK-10
OC-0600-123	12.0	12.3	2100	3.0	14	1.4	1500	6.0	10	1.2	71-80	TK-10
OC-0600-135	12.4	13.5	2100	3.0	14	1.4	1500	6.0	11	1.3	71-80	TK-10
OC-0600-148	13.6	14.8	2100	3.0	15	1.5	1500	6.0	11	1.3	71-80	TK-10
OC-0600-158	14.9	15.8	2100	3.0	16	1.7	1500	6.0	12	1.4	71-80	TK-10
OC-0600-169	15.9	16.9	2100	3.0	17	1.8	1500	6.0	12	1.4	71-80	TK-10
OC-0600-180	17.0	18.0	2100	3.0	18	1.9	1500	6.3	12	1.6	71-80	TK-12-2
OC-0600-185	18.1	18.5	2100	3.0	20	/	1500	6.3	12	1.6	71-80	TK-12-2
OC-0600-190	18.6	19.0	2100	3.0	20	2.1	1500	6.3	13	1.7	71-80	TK-12-2
OC-0600-199	19.1	19.9	2100	3.0	20	2.1	1500	7.9	11	2.7	71-80	TK-12-1
OC-0700-089	8.0	8.9	2200	3.0	11	1.2	1600	6.0	9	1.1	81-90	TK-10
OC-0700-099	9.0	9.9	2200	3.0	12	1.3	1600	6.0	10	1.2	81-90	TK-10
OC-0700-109	10.0	10.9	2200	3.0	12	1.3	1600	6.0	10	1.2	81-90	TK-10
OC-0700-119	11.0	11.9	2200	3.0	13	1.4	1600	6.0	10	1.2	81-90	TK-10
OC-0700-123	12.0	12.3	2200	3.0	14	1.5	1600	6.0	10	1.2	81-90	TK-10
OC-0700-135	12.4	13.5	2200	3.0	14	1.5	1600	6.0	11	1.4	81-90	TK-10
OC-0700-148	13.6	14.8	2200	3.0	15	1.6	1600	6.0	11	1.4	81-90	TK-10
OC-0700-158	14.9	15.8	2200	3.0	16	1.7	1600	6.0	12	1.5	81-90	TK-10
OC-0700-169	15.9	16.9	2200	3.0	17	1.8	1600	6.0	12	1.5	81-90	TK-10
OC-0700-180	17.0	18.0	2200	3.0	18	2.0	1600	6.3	12	1.7	81-90	TK-12-2
OC-0700-185	18.1	18.5	2200	3.0	20	/	1600	6.3	12	1.7	81-90	TK-12-2
OC-0700-190	18.6	19.0	2200	3.0	20	2.2	1600	6.3	13	1.8	81-90	TK-12-2
OC-0700-199	19.1	19.9	2200	3.0	20	2.2	1600	7.9	11	2.9	81-90	TK-12-1
OC-0800-089	8.0	8.9	2300	3.0	11	1.2	1700	6.0	9	1.2	91-100	TK-10
OC-0800-099	9.0	9.9	2300	3.0	12	1.3	1700	6.0	10	1.3	91-100	TK-10
OC-0800-109	10.0	10.9	2300	3.0	12	1.3	1700	6.0	10	1.3	91-100	TK-10
OC-0800-119	11.0	11.9	2300	3.0	13	1.4	1700	6.0	10	1.3	91-100	TK-10
OC-0800-123	12.0	12.3	2300	3.0	14	1.5	1700	6.0	10	1.3	91-100	TK-10
OC-0800-135	12.4	13.5	2300	3.0	14	1.5	1700	6.0	11	1.5	91-100	TK-10
OC-0800-148	13.6	14.8	2300	3.0	15	1.7	1700	6.0	11	1.5	91-100	TK-10
OC-0800-158	14.9	15.8	2300	3.0	16	1.8	1700	6.0	12	1.6	91-100	TK-10
OC-0800-169	15.9	16.9	2300	3.0	17	1.9	1700	6.3	12	1.8	91-100	TK-12-2
OC-0800-180	17.0	18.0	2300	3.0	18	2.0	1700	6.3	12	1.8	91-100	TK-12-2
OC-0800-185	18.1	18.5	2300	3.0	20	/	1700	6.3	12	1.8	91-100	TK-12-2
OC-0800-190	18.6	19.0	2300	3.0	20	2.3	1700	6.3	13	2.0	91-100	TK-12-2
OC-0800-199	19.1	19.9	2300	3.0	20	2.3	1700	7.9	11	3.1	91-100	TK-12-1
OC-0900-119	11.1	11.9	2400	3.0	13	1.5	1800	6.0	10	1.4	101-110	TK-10
OC-0900-123	12.0	12.3	2400	3.0	14	1.6	1800	6.0	10	1.4	101-110	TK-10
OC-0900-135	12.4	13.5	2400	3.0	14	1.6	1800	6.0	11	1.6	101-110	TK-10
OC-0900-148	13.6	14.8	2400	3.0	15	1.8	1800	6.0	11	1.6	101-110	TK-10
OC-0900-158	14.9	15.8	2400	3.0	16	1.9	1800	6.0	12	1.7	101-110	TK-10
OC-0900-169	15.9	16.9	2400	3.0	17	2.0	1800	6.0	12	1.7	101-110	TK-10
OC-0900-180	17.0	18.0	2400	3.0	18	2.1	1800	6.3	12	1.9	101-110	TK-12-2
OC-0900-185	18.1	18.5	2400	3.0	20	/	1800	6.3	12	1.9	101-110	TK-12-2

Catalogue number	Dia. Range		Structural reinforcing rods				Outer rods				RTS (kN)	Clamp body
	Min mm	Max mm	L2 (mm)	Dia. (mm)	Rods no.	Weight (kg)	L1 (mm)	Dia. (mm)	Rods no.	Weight (kg)		
OC-0900-190	18.6	19.0	2400	3.0	20	2.4	1800	6.3	13	2.1	101-110	TK-12-2
OC-0900-199	19.1	19.9	2400	3.0	20	2.4	1800	7.9	11	3.3	101-110	TK-12-1
OC-0900-210	20.0	21.0	2400	3.0	21	2.5	1800	7.9	11	3.3	101-110	TK-12-1
OC-0900-217	21.1	21.7	2400	3.0	22	2.6	1800	7.9	12	3.6	101-110	TK-12-1
OC-0900-224	21.8	22.4	2400	3.0	22	2.6	1800	7.9	12	3.6	101-110	TK-12-1
OC-1000-135	12.4	13.5	2500	3.0	14	1.7	1900	6.0	11	1.7	111-120	TK-10
OC-1000-148	13.6	14.8	2500	3.0	15	1.8	1900	6.0	11	1.7	111-120	TK-10
OC-1000-158	14.9	15.8	2500	3.0	16	2.0	1900	6.0	12	1.8	111-120	TK-10
OC-1000-169	15.9	16.9	2500	3.0	17	2.1	1900	6.0	12	1.8	111-120	TK-10
OC-1000-180	17.0	18.0	2500	3.0	18	2.2	1900	6.3	12	2.0	111-120	TK-12-2
OC-1000-185	18.1	18.5	2500	3.0	20	2.5	1900	6.3	12	2.0	111-120	TK-12-2
OC-1000-190	18.6	19.0	2500	3.0	20	2.5	1900	6.3	13	2.2	111-120	TK-12-2
OC-1000-199	19.1	19.9	2500	3.0	20	2.5	1900	7.9	11	3.5	111-120	TK-12-1
OC-1000-210	20.0	21.0	2500	3.0	21	2.6	1900	7.9	11	3.5	111-120	TK-12-1
OC-1000-217	21.1	21.7	2500	3.0	22	2.8	1900	7.9	12	3.8	111-120	TK-12-1
OC-1000-224	21.8	22.4	2500	3.0	22	2.8	1900	7.9	12	3.8	111-120	TK-12-1

### Several connection styles of Single suspension set with tower

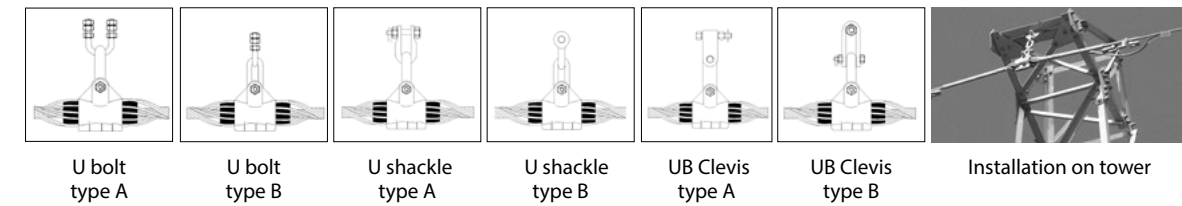

### Double Suspension Set for OPGW

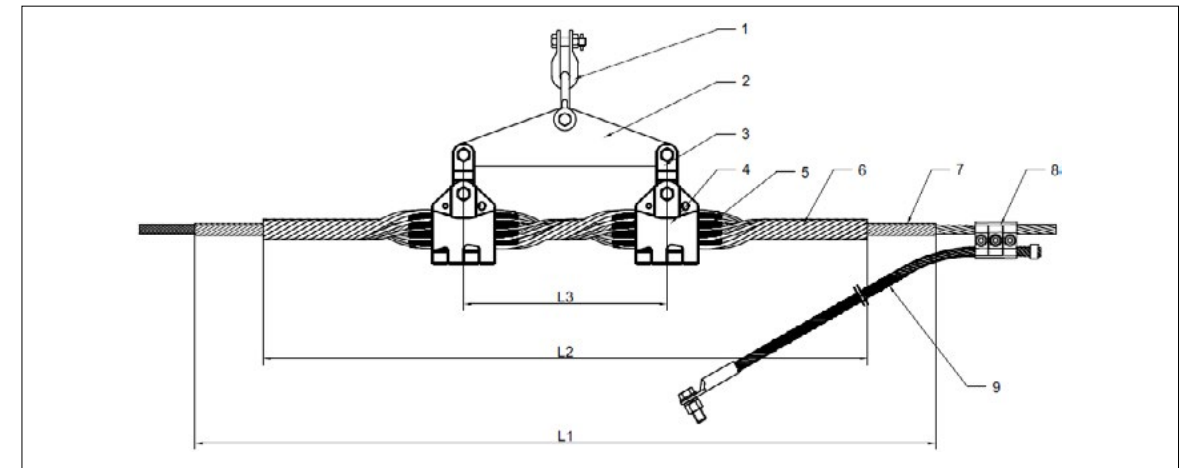

1. U shackle: Galvanized steel
2. Yoke plate: Galvanized steel
3. PS clevis: Galvanized steel
4. Clamp body: Aluminum alloy
5. Insert: EPDM
6. Outer rods: High strength aluminum alloy
7. Structural reinforcing rods: Aluminum-clad steel
8. Parallel groove clamp: Aluminum alloy
9. Ground wire set: Aluminum

Note: 1. The shapes for both no. 3 clamp body and no. 7 parallel groove clamp are determined by OPGW's diameter, which in the above drawing are just for reference.

2. For other requirements or more information, please consult ZTT.



### Consideration

- Mainly used in long span rivers and valleys with large drop in level. Used on poles or tower whose turning corner is from 30 degree to 60 degrees.
- Normally, the span length of Yoke plate is 400mm, which can be manufactured according to customers' requirement.

Table C-1 Double Suspension set for OPGW

Catalogue number	Dia. Range		Structural reinforcing rods				Outer rods				RTS Range (kN)	Distance L3 (mm)	Clamp body
	Min mm	Max mm	L2 (mm)	Dia. (mm)	Rods no.	Weight (kg)	L1 (mm)	Dia. (mm)	Rods no.	Weight (kg)			
OSC-089-400-100	8.0	8.9	2260	3.0	11	1.2	1660	6.0	9	1.2	≤100	400	TK-10
OSC-099-400-100	9.0	9.9	2260	3.0	12	1.3	1660	6.0	10	1.3	≤100	400	TK-10
OSC-109-400-100	10.0	10.9	2260	3.0	12	1.3	1660	6.0	10	1.3	≤100	400	TK-10
OSC-119-400-100	11.0	11.9	2260	3.0	13	1.4	1660	6.0	10	1.3	≤100	400	TK-10
OSC-123-400-100	12.0	12.3	2260	3.0	14	1.6	1660	6.0	10	1.3	≤100	400	TK-10
OSC-135-400-100	12.4	13.5	2260	3.0	14	1.6	1660	6.0	11	1.5	≤100	400	TK-10
OSC-148-400-100	13.6	14.8	2260	3.0	15	1.7	1660	6.0	11	1.5	≤100	400	TK-10
OSC-158-400-100	14.9	15.8	2360	3.0	16	1.9	1760	6.0	12	1.7	≤100	400	TK-10
OSC-164-400-100	15.9	16.4	2360	3.0	17	2.0	1760	6.0	12	1.7	≤100	400	TK-10
OSC-169-400-100	16.5	16.9	2460	3.0	17	2.1	1860	6.0	12	1.7	≤100	400	TK-10
OSC-180-450-120	17.0	18.0	2560	3.0	18	2.3	1960	6.3	12	2.1	≤120	450	TK-12-2
OSC-185-450-120	18.1	18.5	2560	3.0	19	2.4	1960	6.3	12	2.1	≤120	450	TK-12-2
OSC-190-450-120	18.6	19.0	2560	3.0	20	2.5	1960	6.3	13	2.1	≤120	450	TK-12-2
OSC-199-660-120	19.1	19.9	2560	3.0	20	2.5	2060	7.9	11	3.8	≤120	660	TK-12-1
OSC-089-400-160	8.0	8.9	2660	3.0	11	1.4	2000	6.0	9	1.4	101-160	400	TK-10
OSC-099-400-160	9.0	9.9	2660	3.0	12	1.5	2000	6.0	10	1.6	101-160	400	TK-10
OSC-109-400-160	10.0	10.9	2660	3.0	12	1.5	2000	6.0	10	1.6	101-160	400	TK-10
OSC-119-400-160	11.0	11.9	2660	3.0	13	1.7	2000	6.0	10	1.6	101-160	400	TK-10
OSC-123-400-160	12.0	12.3	2660	3.0	14	1.8	2000	6.0	10	1.6	101-160	400	TK-10
OSC-135-400-160	12.4	13.5	2660	3.0	14	1.9	2000	6.0	11	1.7	101-160	400	TK-10
OSC-148-400-160	13.6	14.8	2660	3.0	15	2.0	2000	6.0	11	1.8	101-160	400	TK-10
OSC-158-400-160	14.9	15.8	2760	3.0	16	2.2	2100	6.0	12	2.0	101-160	400	TK-10
OSC-164-400-210	15.9	16.4	2760	3.0	17	2.3	2100	6.0	12	2.0	101-210	400	TK-10
OSC-169-400-210	16.5	16.9	2860	3.0	17	2.4	2260	6.0	12	2.2	101-210	400	TK-10
OSC-180-450-210	17.0	18.0	2960	3.0	18	2.6	2360	6.3	12	2.5	121-210	450	TK-12-2
OSC-185-450-210	18.1	18.5	2960	3.0	19	2.8	2360	6.3	12	2.5	121-210	450	TK-12-2
OSC-190-450-210	18.6	19.0	2960	3.0	20	2.9	2360	6.3	13	2.7	121-210	450	TK-12-2
OSC-199-660-210	19.1	19.9	3060	3.0	20	3.0	2460	7.9	11	4.5	121-210	660	TK-12-1
OSC-210-660-210	20.0	21.0	3060	3.0	21	3.2	2460	7.9	11	4.5	121-210	660	TK-12-1
OSC-217-660-210	21.1	21.7	3060	3.0	22	3.4	2460	7.9	12	4.9	121-210	660	TK-12-1
OSC-224-660-210	21.8	22.4	3060	3.0	22	3.4	2460	7.9	12	4.9	121-210	660	TK-12-1

### Several connection styles of Single suspension set with tower

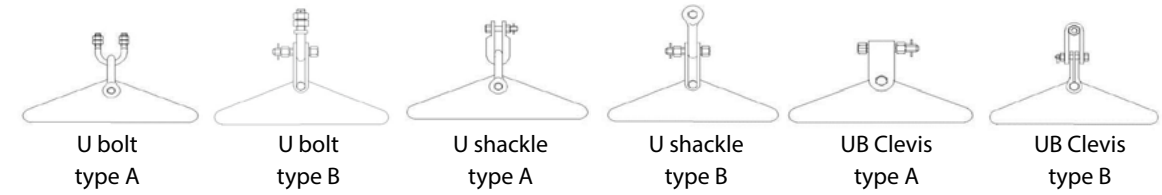

### suspension clamp body

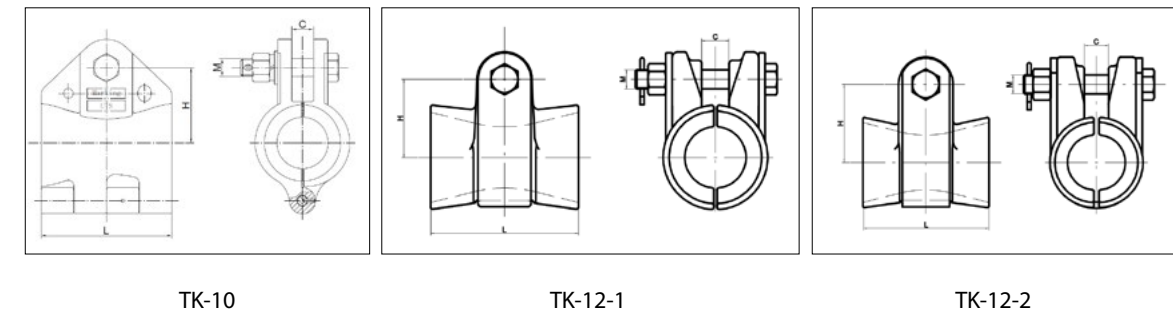
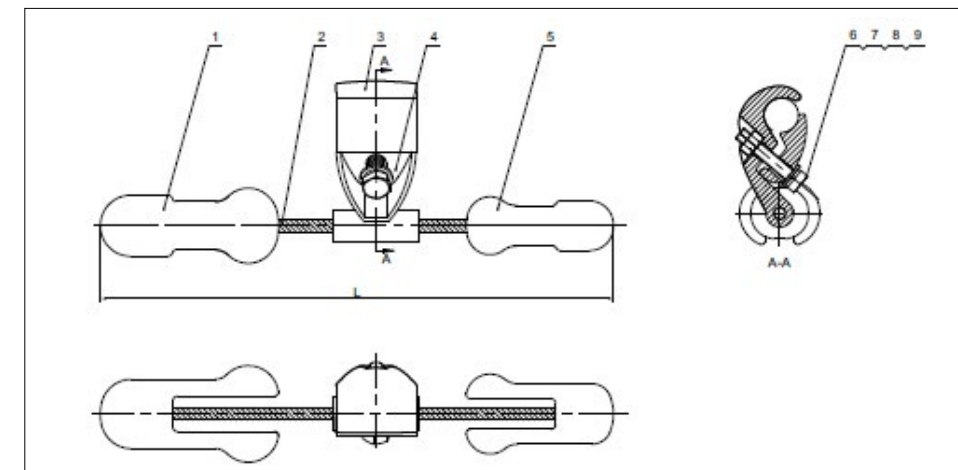

Table C-2 Suspension clamp body

Catalogue number	UTS (kN)	Dimension (mm)				Weight (kg)
		C	H	M	L	
TK-10	100	20	69	M16	120	1.2
TK-12-1	120	26	75	M18	410	2.6
TK-12-2	120	23	72.5	M18	120	2.3

### ■ Vibration Damper (4D Series)



- 1. Large Weight: Cast Iron
- 2. Messenger cable: Galvanized steel
- 3. Clamp body: Aluminum Alloy
- 4. Clamp keeper: Aluminum Alloy
- 5. Small Weight: Cast Iron
- 6,7,8,9 Bolt Assembly: Galvanized steel

### Product Characteristic

- The weights of 4D series damper are different, small one and large one. This type damper has 4 resonant frequencies from 6Hz to 120Hz, allowing the dampers to be effective across a much wider frequency range than standard Stockbridge dampers.
- Connection weights with messenger cable by glue, offering better damper effectiveness and working life.
- The 4D series dampers are suitable for use on all earth wire constructions including galvanized steel wire, aluminum-clad steel wire with covering the range of sizes from 7.5mm to 34mm.

### Consideration

- The maximum recommended line angle for a single suspension set is 30°. Double one is recommended for OPGW line angle between 30° and 60°.
- The standard products are suitable for Right-hand lay OPGW (outer layer). If the outer layer of OPGW is Left-hand lay, please specify.
- Once installed, do not reuse the rod components. The hardware components may be reused as desired as long as they are in good condition. Do not modify any components.
- Dampers must be adapted to the conductor. If not, damper can cause destruction to the cable or be destroyed by itself.
- For optimal effectiveness of damper, it is necessary to choose the right damper type, to install at the exact locations, and to install the reasonable quantity of dampers.
- In general, the installing direction of dampers will not influence damper's efficiency. However, ZTT advises that the large weight of the damper is installed on the tower side.

Table D-1 Catalogue Table of 4D series Vibration Damper

Catalogue number	Clamping range (mm)	Cable Dia. range (mm)	Total Length L(mm)	Width of clamp (mm)	Height of clamp H(mm)	Weight (kg)
4D-20	15.0-21.0	8.0-15.0	319	53	73	1.5
4D-30	21.0-26.0	15.0-20.0	391	53	73	2.7
4D-40	26.0-30.0	20.0-24.0	479	65	93	4.7

### Armor rods for Vibration Damper

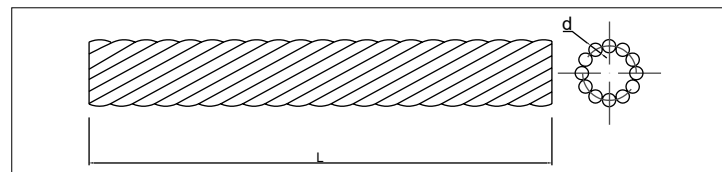

To avoid the surface of OPGW damaged by vibration damper clamp, the armor rods are assembled together with damper on OPGW.

Table D-2 Armor for Vibration Damper

Catalogue number	Cable diameter (mm)	Length L(mm)	Diameter d(mm)	No. of rods
HXT-420-0890	8.0-8.9	420	3.5	9
HXT-420-0990	9.0-9.9	420	3.5	9
HXT-420-1090	10.0-10.9	420	3.5	10
HXT-420-1190	11.0-11.9	420	3.5	11
HXT-420-1240	12.0-12.4	420	3.5	12
HXT-420-1290	12.5-12.9	420	3.5	12
HXT-420-1390	13.0-13.9	420	3.5	13
HXT-420-1490	14.0-14.9	420	3.5	14
HXT-420-1540	15.0-15.4	420	3.5	15
HXT-420-1590	15.5-15.9	420	3.5	15
HXT-420-1690	16.0-16.9	420	3.5	15
HXT-420-1790	17.0-17.9	420	3.5	16
HXT-420-1890	18.0-18.9	420	3.5	17

### Consideration

- The armor rods are made of aluminum alloy. Generally, the parameter of length 420mm and diameter 3.0mm or 4.0mm of rods are sufficient for vibration damper installation. The dimensions could be adjusted according to customer's requirement.
- The diameter of OPGW must be available when order placed.

### Ground Wire Set

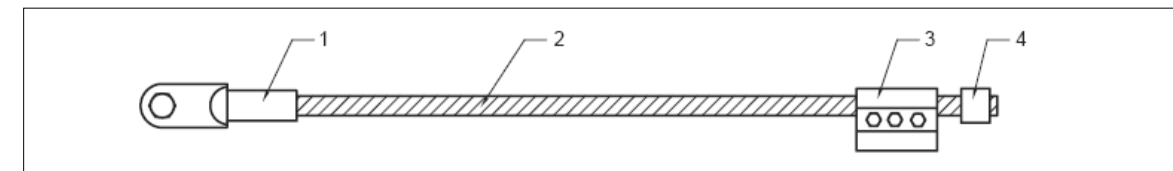

- 1.Cable lug: Aluminum
- 2.Ground wire: Aluminum
- 3.Parallel groove clamp: Aluminum alloy
- 4.Aluminum tight tube: Aluminum

Table E-1 Catalogue Table of Ground Wire Set

Catalogue Number	OPGW Cable diameter(mm)	Section area of wire (mm <sup>2</sup> )	Length (mm)	Parallel Groove clamp
JDX-95-2000	7.0-17.0	95	2000	JBL-16-120B
JDX-120-2000	17.1-20.0	120	2000	JBL-50-240B
JDX-150-2000	20.1-22.0	150	2000	JBL-120-400B
JDX-185-2000	> 22.0	185	2000	JBL-120-400B

Note: The cross section and length for the Ground wire can be customized according to customers' requirements.



## PTK Joint Box

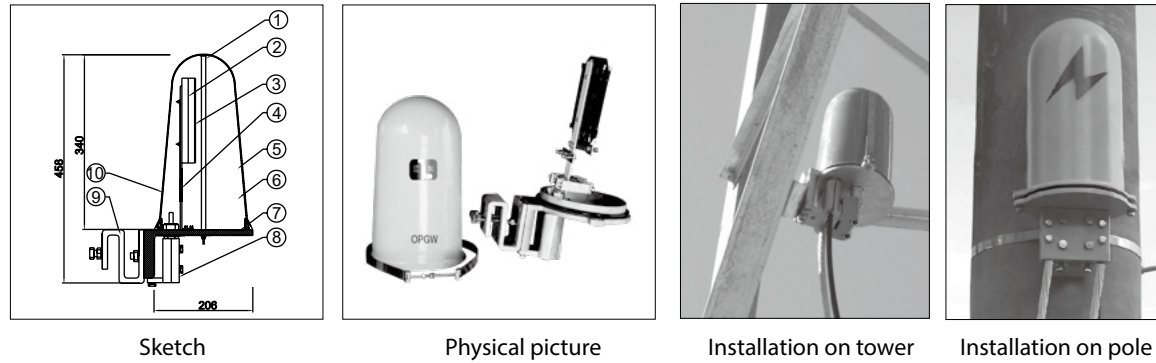

- |  |   |
|--|---|
| <ol style="list-style-type: none"> <li>1. Top lock ribbon: Stainless steel</li> <li>2. Fiber coiling sheet: Plastic</li> <li>3. Fiber coiling sheet cover: Plastic</li> <li>4. Tray sheet tighten tray support: Steel</li> <li>5. Adapter: Aluminum alloy</li> </ol> | <ol style="list-style-type: none"> <li>6. Joint box body: Die-casting Aluminum alloy</li> <li>7. Joint box body's seal ring: Rubber</li> <li>8. Front and back clips outside the box: Aluminum alloy</li> <li>9. "S" Tighten steel: Galvanized steel</li> <li>10. Joint box cover: Aluminum alloy or Stainless steel</li> </ol> |
|--|---|

### Product Characteristic

- |  |   |
|--|---|
| <ul style="list-style-type: none"> <li>• The cover is made of high density aluminum alloy</li> <li>• The jointing parts and fixing parts are made of high quality stainless steel and cast steel</li> <li>• Repeated used, easy to re-joint and expand capacity</li> <li>• Installed on tower or pole alternatively</li> </ul> | <ul style="list-style-type: none"> <li>• Good mechanical, sealing and anti-corrosion performance</li> <li>• Straight through or branched splice application, has 1 in 1 out, 1 in 2 out, 2 in 2 out function, Up to 6 cable ports.</li> </ul> |
|--|---|

### Technical specifications

- |  |  |
|--|--|
| <ul style="list-style-type: none"> <li>• Fiber bending additional attenuation: <math>\leq 0.01</math>dB</li> <li>• Fiber bending radius: <math>\geq 30</math>mm</li> <li>• Retaining fiber length: <math>\geq 1.6</math>m</li> </ul> | <ul style="list-style-type: none"> <li>• Tensile crush resistance: 2000N/100mm</li> <li>• Environment temperature: <math>-40^{\circ}\text{C} \sim +65^{\circ}\text{C}</math></li> <li>• Maximum fibers splice capacity: 96D</li> </ul> |
|--|--|

## SJD Joint Box

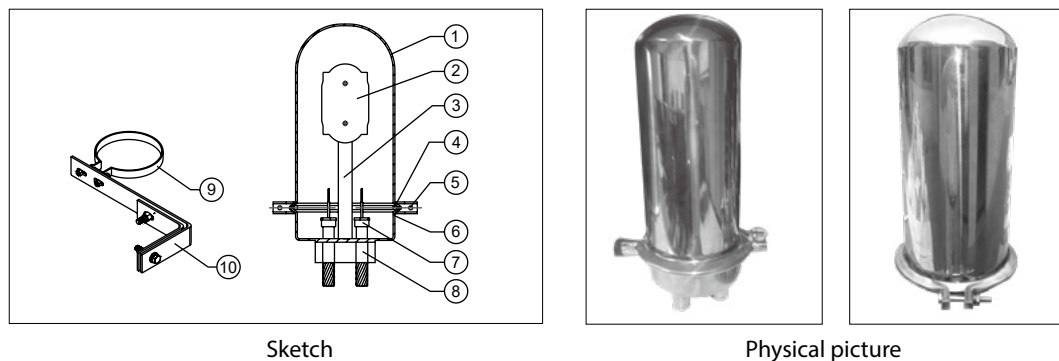

- |  |   |
|--|---|
| <ol style="list-style-type: none"> <li>1. Joint box cover: Stainless steel</li> <li>2. Fiber coiling Tray: ABS</li> <li>3. Tray support: steel, h.d.g.</li> <li>4. Joint box body's seal ring: EPDM</li> <li>5. Hoop: Stainless Steel</li> </ol> | <ol style="list-style-type: none"> <li>6. Bottom Base: Stainless Steel</li> <li>7. Sealing Device</li> <li>8. Fixture Clamp: Stainless Steel</li> <li>9. <math>\Omega</math> Hoop: steel, h.d.g.</li> <li>10. Tower Clamp: steel, h.d.g.</li> </ol> |
|--|---|

### Product Characteristic

- |  |   |
|--|---|
| <ul style="list-style-type: none"> <li>• The shell is made of Stainless steel</li> <li>• The jointing parts and fixing parts are made of high quality stainless steel and cast steel</li> <li>• Repeated used, easy to re-joint and expand capacity</li> <li>• Installed on tower or pole alternative</li> </ul> | <ul style="list-style-type: none"> <li>• Good mechanical, sealing and anti-corrosion performance</li> <li>• Straight through or branched splice application, has 1 in 1 out, 1 in 2 out, 2 in 2 out function</li> </ul> |
|--|---|

### Technical specifications

- |   |  |
|---|--|
| <ul style="list-style-type: none"> <li>• Fiber bending additional attenuation: <math>\leq 0.01</math>dB</li> <li>• Fiber bending radius: <math>\geq 30</math>mm</li> <li>• Retaining fiber length: <math>\geq 1.6</math>m</li> <li>• Tensile crush resistance: 2000N/100mm</li> </ul> | <ul style="list-style-type: none"> <li>• Environment temperature: <math>-40^{\circ}\text{C} \sim +65^{\circ}\text{C}</math></li> <li>• Maximum fibers splice capacity: 144D</li> <li>• Bullet proof</li> </ul> |
|---|--|

## STD/STB Joint Box

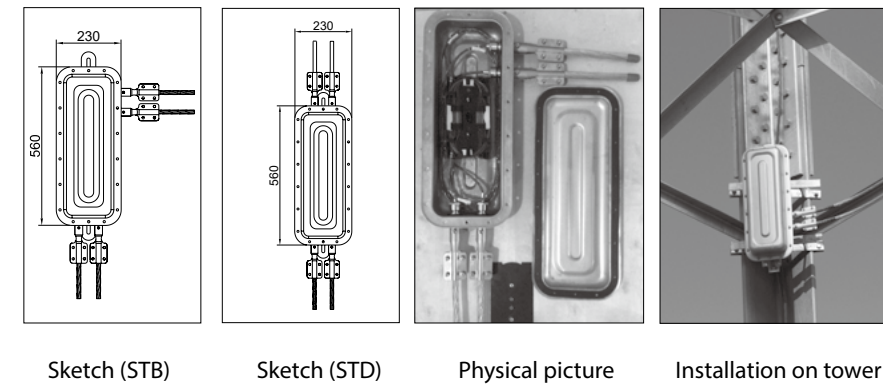

- |   |  |
|---|--|
| <ul style="list-style-type: none"> <li>• Joint box body &amp; cover: Stainless steel</li> <li>• Fiber coiling Tray assembly: plastic</li> </ul> | <ul style="list-style-type: none"> <li>• Joint box body's seal ring: rubber</li> <li>• Tower Clamp assembly: Steel h.d.g.</li> </ul> |
|---|--|

### Product Characteristic

- |   |   |
|---|---|
| <ul style="list-style-type: none"> <li>• The shell is made of Stainless steel</li> <li>• The jointing parts and fixing parts are made of high quality steel</li> <li>• Repeated used, easy to re-joint and expand capacity</li> <li>• Installed on tower or pole alternative</li> </ul> | <ul style="list-style-type: none"> <li>• Good mechanical, sealing and anti-corrosion performance</li> <li>• Straight through or branched splice application, has 1 in 1 out, 1 in 2 out, 2 in 2 out function</li> </ul> |
|---|---|

### Technical specifications

- |  |   |
|--|---|
| <ul style="list-style-type: none"> <li>• Fiber bending additional attenuation: <math>\leq 0.01</math>dB</li> <li>• Fiber bending radius: <math>\geq 30</math>mm</li> <li>• Retaining fiber length: <math>\geq 1.6</math>m</li> </ul> | <ul style="list-style-type: none"> <li>• Tensile crush resistance: 2000N/100mm</li> <li>• Environment temperature: <math>-40^{\circ}\text{C} \sim +65^{\circ}\text{C}</math></li> <li>• Maximum fibers splice capacity: 192D or 288D</li> </ul> |
|--|---|

## ■ Cable Tray (Cable Storage) for OPGW

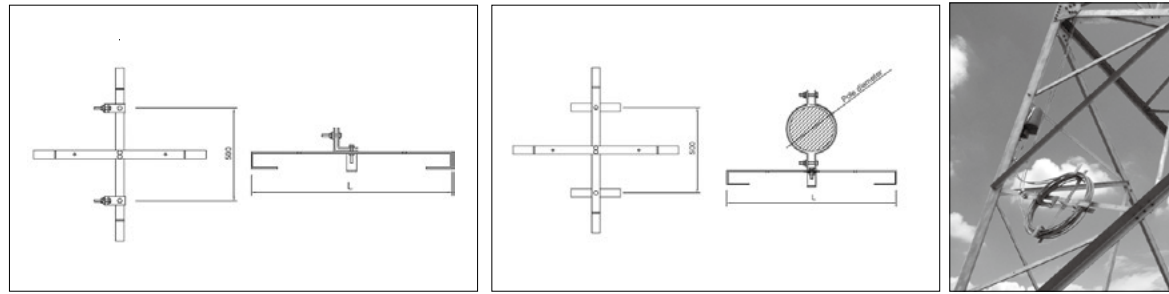

Sketch(on tower)

Sketch(on pole)

Installation on tower

### Consideration

- The cable tray is used to retain the left OPGW when OPGW's jointing. Normally, one Joint Box is assembled with one Cable Tray.
- The diameter of Pole must be available when order placed.
- The length L could be adjusted according to customer's requirement.

### Catalogue Table of Cable tray for OPGW

Catalogue Number	Length L(mm)	Mass(Kg)	Mark
O-YLJ-T-800	800	5.0	For tower
O-YLJ-T-1000	1000	7.0	For tower
O-YLJ-T-1200	1200	9.4	For tower
O-YLJ-G-800	800	5.0	For pole
O-YLJ-G-1000	1000	7.0	For pole
O-YLJ-G-1200	1200	9.4	For pole

## ■ Downlead for OPGW

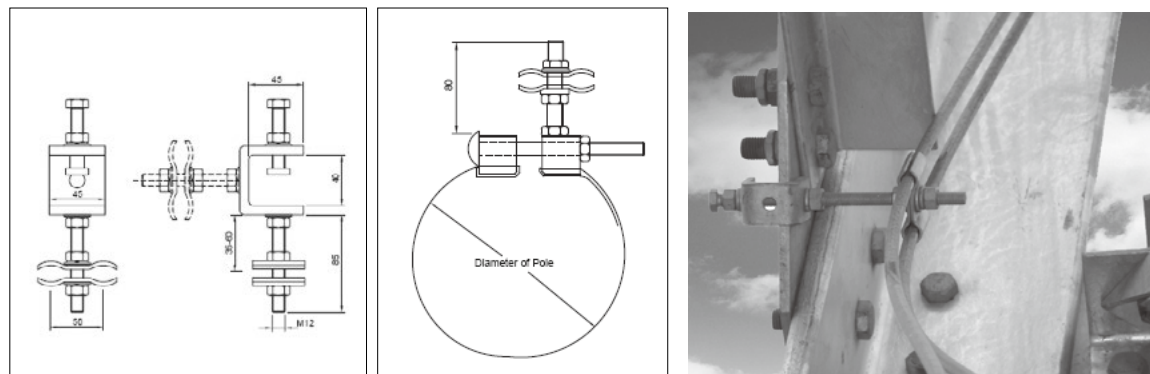

For tower

For pole

Installation on tower

### Products Characteristic

- The downlead is made of galvanized steel except the band of downlead for pole, which made of stainless steel.
- The downlead for tower could be adjusted 90° in direction.

### Consideration

- The diameter of pole must be available when order placed.

# Helical Fittings and Accessories for ADSS

## ■ Dead-end Set for ADSS

Span  $\leq$  150m and RTS  $\leq$  15kN dead-end set

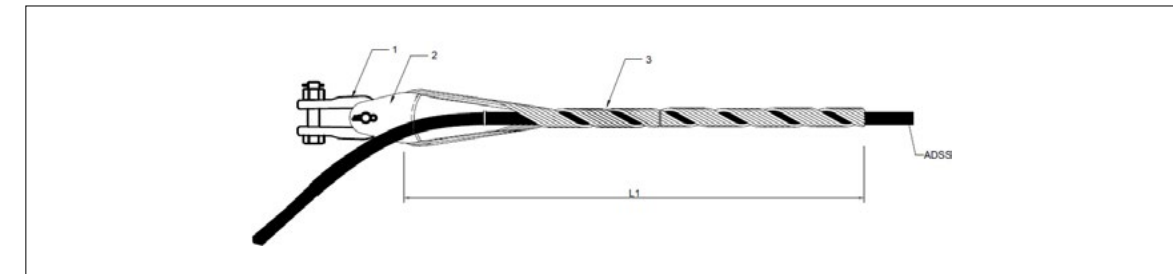

1. Bow shackle: Galvanized steel
2. Thimble Clevis: Galvanized steel

3. Dead-end component: Aluminum-clad steel

150m < Span  $\leq$  400m and 15kN < RTS  $\leq$  40kN dead-end set

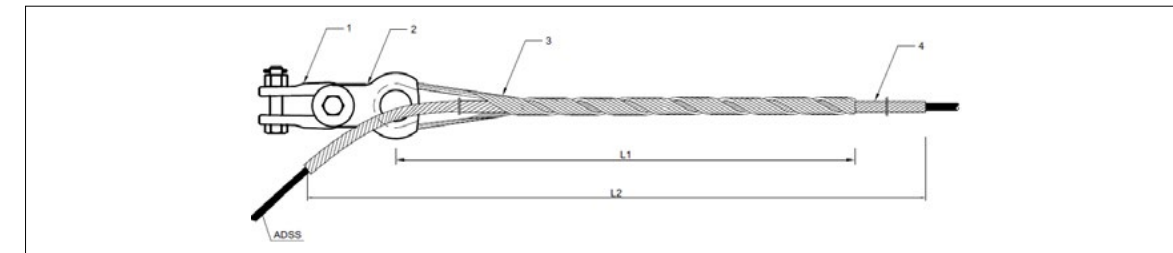

1. Bow shackle: Galvanized steel
2. Thimble Clevis: Galvanized Cast Iron

3. Dead-End Component: Aluminum-Clad Steel
4. Structural Reinforcing Rods: Aluminum-Clad Steel

400m < Span  $\leq$  800m and 40kN < RTS  $\leq$  70kN dead-end set

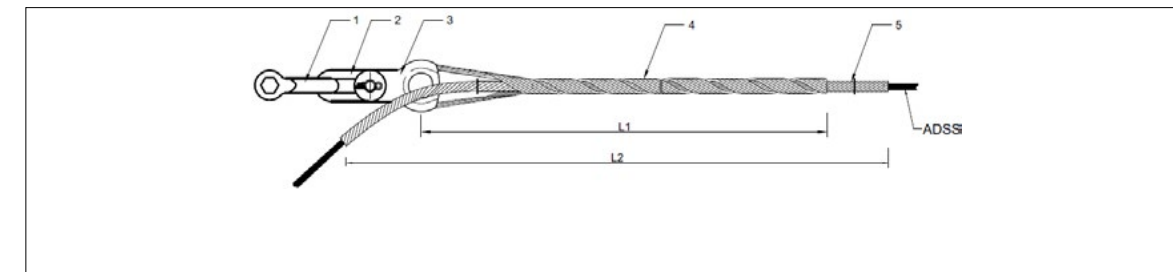

1. U Shackle: Galvanized Steel
2. Extensive Link: Galvanized Steel
3. Thimble Clevis: Galvanized Cast Iron

4. Dead-End Component: Aluminum-Clad Steel
5. Structural Reinforcing Rods: Aluminum-Clad Steel



### Product Characteristic

- The helical formed wire inner and outer layer components are designed to transfer axial tensile loads and distribute radial compressive forces over the surface in contact with the ADSS to minimize effects on the central core and internal optical fibers.
- The inside of inner and outer rods covered with silicon carbide, increasing frictional force and damping effects.
- Minimum holding strength of dead-end set not less than 75% RTS of cable.
- Excellent anti-fatigue characteristic.
- The installation is convenient, no special tools needed

### Consideration

- Once installed, structural reinforcing rods and dead-end component may be removed and reinstalled once for repositioning purpose. Do not reuse after this initial installation. The hardware components may be reused as long as they are in good condition. Do not modify any components.
- Right-hand lay is standard. Left-hand lay is available.
- Contact us in advance for the requirement of left-hand lay dead-end clamp.
- U shackle, PD Link and other hardware accessories may be ordered with the dead-end.
- The fittings can only be installed by experienced workers.

### Catalogue table of Dead-end for ADSS

Catalogue Number	Suitable strength(kN)	Span(m)	Structural reinforcing rods (mm)		Dead-end (mm)		Reference span length (m)
			Length L2	Diameter	Length L1	Diameter	
AN-010-****	≤15	—	—	1340	2.5	2.5	≤150
AN-020-****	16-20	1500	2.5	1100	3.5	3.5	150-200
AN-030-****	21-30	1600	2.5	1200	3.5	3.5	201-300
AN-040-****	31-40	1700	2.5	1400	3.5	3.5	301-400
AN-050-****	41-50	1800	2.5	1400	3.5	3.5	401-500
AN-060-****	51-60	2300	2.5	1600	4.0	4.0	501-600
AN-070-****	61-70	2400	2.5	1700	4.0	4.0	601-800
AN-AAA-****	≥71	2500	2.5	1800	4.8	4.8	801-1000

Note: \*\*\*\*-- is on behalf of ADSS diameter, e.g. 1350 indicates the diameter of ADSS is 13.50mm.  
AAA-- is RTS of ADSS, for example, if RTS is 75.2 kN, AAA is '080'.

### Installation Diagram



Joint Pole

Terminal Pole

Pass Pole

The installation diagrams on tower are same as OPGW

### Single Suspension Set

#### Small span suspension set

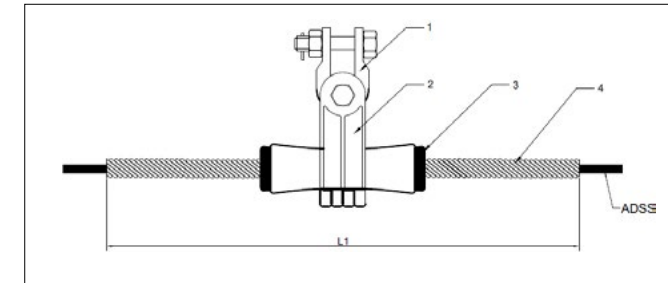

- U Shackle: Galvanized Steel
- Aluminum Clamp: Aluminum Alloy
- Rubber Insert: EPDM
- Reinforcing Rods: Aluminum-Clad Steel

### Products Characteristic

- Single structure, with only one layer rods;
- Suitable for span length is less than 100m, and the turning angle less than 20°

#### Small span suspension set

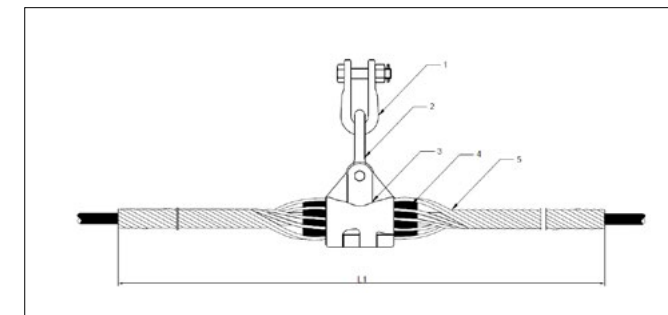

- U Shackle: Galvanized Steel
- Eye Link: Galvanized Steel
- Aluminum Clamp: Aluminum Alloy
- Elastomer Insert: EPDM
- Outer Rods: High Strength Aluminum Alloy

### Products Characteristic

- Single structure, with only one outer layer rods;
- Suitable for span length is less than 200m, and the turning angle is less than 30°

#### Normal suspension set for ADSS

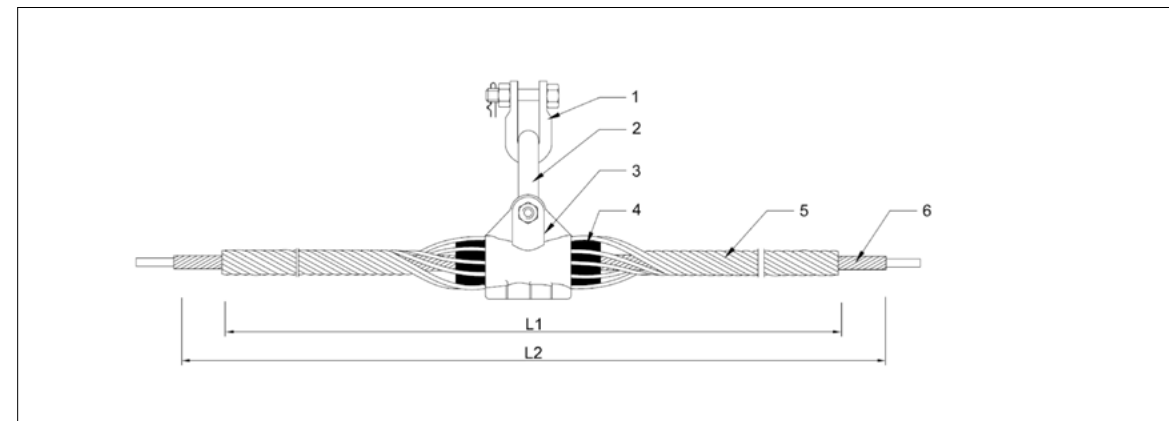

- U Shackle: Galvanized Steel
- Eye Link: Galvanized Steel
- Aluminum Clamp: Aluminum Alloy
- Elastomer Insert: EPDM
- Outer Rods: High Strength Aluminum Alloy
- Structural Reinforcing Rods: Aluminum Alloy

### Product Characteristic

- The suspension set provides superior cable and fiber protection at the support point. The combination of Structural reinforcing rods, Outer rods, boltless housing and resilient Insert reduces compression, clamping and bending stresses on cable. Negative weather-related cable motion, such as Aeolian vibration, galloping, and wind sway are also minimized.
- The insert for resistance to ozone attack, weathering, extreme high and low temperature variations. An aluminum alloy reinforcement is molded into the elastomer.
- The slip load of suspension set can reach approximate 14% of ADSS rated strength to offer sufficient holding strength for ADSS.

### Consideration

- The maximum recommended line angle for a single suspension set is 30°. Double suspension is recommended for ADSS line angle between 30° and 60°.
- Once installed, do not reuse the rod components. The hardware components may be reused as desired as long as they are in good condition. Do not modify any components.

### Catalogue Table of Normal Suspension set for ADSS

Catalogue Number	Reference span length (m)	Structural reinforcing rods(mm)		Outer rods(mm)	
		Length L2	Diameter	Length L2	Diameter
AC-0100-****	≤100	800	2.5	—	—
AC-0200-****	101-200	—	—	1400	4.6
AC-0300-****	201-300	1600	3.5	1200	6.0
AC-0400-****	301-400	1700	3.5	1300	6.0
AC-0500-****	401-500	1800	3.5	1400	6.0
AC-0600-****	501-600	1900	3.5	1500	6.0
AC-0700-****	601-700	2000	3.5	1600	6.0
AC-0800-****	701-800	2100	3.5	1700	6.0
AC-0900-****	801-900	2200	3.5	1800	6.0

Note: \*\*\*\* is on behalf of ADSS diameter, e.g. 1350 indicates the diameter of ADSS is 13.50mm.

### Double Suspension Set for ADSS

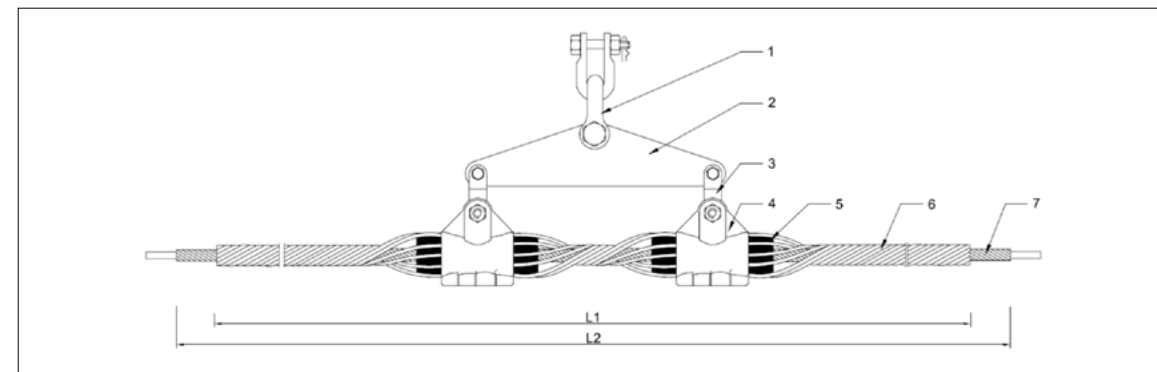

- |                                   |  |
|-----------------------------------|--|
| 1. U Shackle: Galvanized Steel    | 5. Elastomer Insert: EPDM                      |
| 2. Yoke Plate: Galvanized Steel   | 6. Outer Rods: High Strength Aluminum Alloy    |
| 3. PS Clevis: Galvanized Steel    | 7. Structural Reinforcing Rods: Aluminum Alloy |
| 4. Aluminum Clamp: Aluminum Alloy |  |

### Consideration

- Mainly used in long span rivers and valleys with large drop in level.
- Used on poles or tower which turning corner is from 30 degree to 60 degree.
- Normally, the span length of Yoke plate is 400mm. It can be adjusted according to customers' requirement.

### Catalogue Table of Double suspension set

Catalogue Number	Range Diameter(mm)	Range Diameter(mm)	Structural reinforcing rods(mm)		Outer rods(mm)	
			Length L2	Diameter	Length L1	Diameter
ASC-****-400	9.0~15.0	2260	3.5	1660	6.0	6.0
ASC-****-400	15.1~16.4	2360	3.5	1760	6.0	6.0
ASC-****-450	16.5~17.0	2460	3.5	1860	6.3	6.3
ASC-****-450	17.0~18.0	2560	3.5	1960	6.3	7.9
ASC-****-660	> 18.1	2660	3.5	2060	7.9	6.0

Note: \*\*\*\* on behalf of diameter of ADSS; '400', '450' and '660' on behalf of span length of Yoke plate.

### Installation Diagram



Installation on pole

### Spiral Vibration Damper

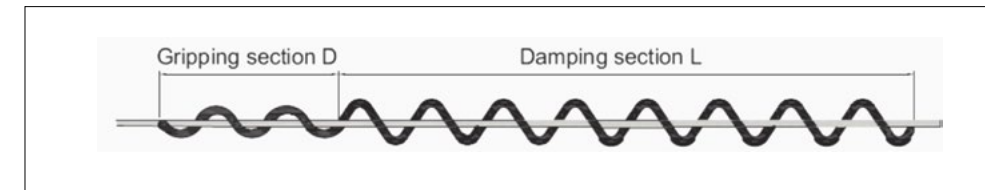

### Product Characteristic

- Effectively reduces levels of Aeolian vibration on cables. Has a helically formed dampening section sized for ADSS cables tend to vibrate at higher levels than other cables of comparable size, mainly due to their relatively lighter weight. Also the soft nature of their jackets and internal construction requires special consideration.
- interplay of damper and cable, to provide the action/reaction motion that opposes the natural vibration wave. A smaller gripping section gently grips the cable so that cable and fiber are not damaged or distorted and there is no optical signal loss.

### Consideration

- Consult ZTT for recommendation on the number of damper required per span.

### Catalogue Table of Normal Suspension set for ADSS

Catalogue number		Dia (mm)	Length (mm)	Suitable cable diameter (mm)
Normal type	Resistance to E-corrosion type			
FLP-10	FLN-10	350	1050	φ10.39-φ11.70
FLP-11	FLN-11			φ11.71-φ13.0
FLP-12	FLN-12			φ13.01-φ14.30
FLP-12.5	FLN-12.5			φ14.31-φ15.70
FLP-13	FLN-13			φ15.71-φ17.10
FLP-14	FLN-14			φ17.11-φ18.50
FLP-16	FLN-16			φ18.51-φ20.00
FLP-17	FLN-17			φ20.01-φ21.50
FLP-18	FLN-18			φ21.51-φ22.90



## Installation Diagram



## ■ Corona Coil

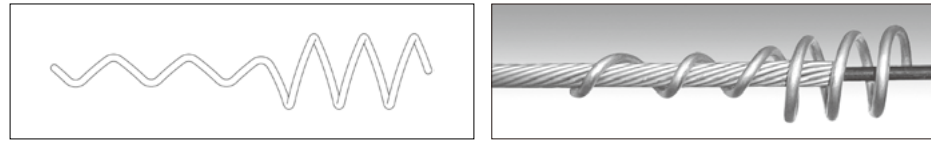

### Product Characteristic

- Corona coils are made of aluminum alloy, intended to reduce electrical stress at the ends of the metal rods of Dead-ends and Suspensions applied on ADSS cables installed in high voltage electrical fields. They are made from a light weight material and are designed to suppress electrical arcing at the ends of metal rods which can occur on some lines and may damage the plastic jacket of ADSS cables.
- The unit is secured in place by wrapping the unique gripping section directly over the Structural Reinforcing Rods of a dead-end and suspension. They will not interfere with the performance of the dead-end or the suspension.

### Consideration

- Position the Corona Coil so all the ends of the Structural Reinforcing Rods fall completely inside the coil section, and try to align the rods in the center of the coil.
- This product may be removed and reinstalled during the initial installation if it is in good condition.

## ■ Download

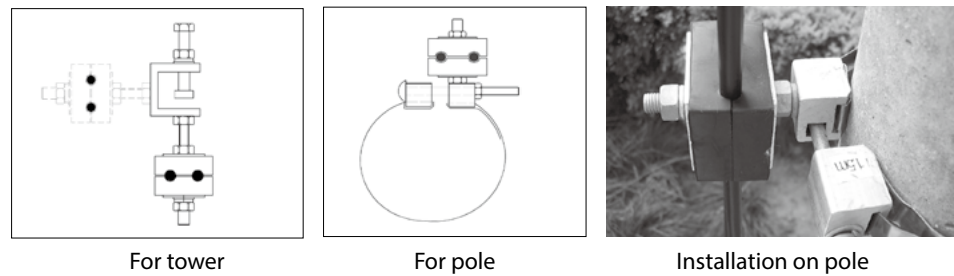

### Products Characteristic

- The download clamp is made of EPDM, protecting the cable well.
- The download for tower could be adjusted 90° in direction.

### Consideration

- The diameter of pole must be available when order placed.

## ■ Tray and Joint Box

The ADSS's cable tray and joint box are similar as OPGW's.

### Catalogue Table of Cable tray for ADSS

Catalogue Number	Length L(mm)	Mark
A-YLJ-T-660	660	For tower
A-YLJ-G-660	660	For pole

### Installation Diagram



Installation on tower Installation on pole

## ■ Fastened Fittings

### ● Fastened Fittings for Pole

We design series of fastened fittings for standard towers according to actual installation conditions and primary material size. They could be manufactured according to customer's requirement.

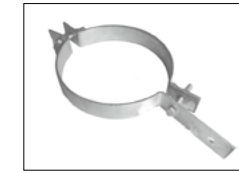

For tension / suspension set (TGX)

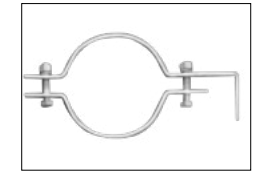

For Joint box / Cable tray (TGJ)

### Catalogue Table for tension set and suspension set

Catalogue Number	Suitable Range (mm)	Material	Breaking Load (KN)
TGX 070 165	For the diameter 165 Pole	Galv. Steel	70
TGX 070 190	For the diameter 190 Pole	Galv. Steel	70
TGX 070 210	For the diameter 210 Pole	Galv. Steel	70
TGX 070 230	For the diameter 230 Pole	Galv. Steel	70
TGX 070 260	For the diameter 260 Pole	Galv. Steel	70
TGX 070 300	For the diameter 300 Pole	Galv. Steel	70
TGX 070 400	For the diameter 400 Pole	Galv. Steel	70

### For Joint box and Cable tray

Catalogue Number	Suitable Range (mm)	Material	Breaking Load (KN)
TGJ 030 165	For the diameter 165 Pole	Galv. Steel	30
TGJ 030 190	For the diameter 190 Pole	Galv. Steel	30
TGJ 030 210	For the diameter 210 Pole	Galv. Steel	30
TGJ 030 230	For the diameter 230 Pole	Galv. Steel	30
TGJ 030 260	For the diameter 260 Pole	Galv. Steel	30
TGJ 030 300	For the diameter 300 Pole	Galv. Steel	30
TGJ 030 400	For the diameter 400 Pole	Galv. Steel	30

### ● Fastened Fittings for Tower



For suspension tower(TTZX)



For tension tower(TTZJ)



For cable tray (TTJG)



G Support for suspension (G)

### Catalogue Table

Catalogue table	Suitable Range	Material	Breaking Force (kN)
TTZX 070 080	Dimension of Linking Parts≤80mm	Galv. steel	70
TTZX 070 100	Dimension of Linking Part 81~100mm	Galv. steel	70
TTZX 070 125	Dimension of Linking Part 101~125mm	Galv. steel	70
TTZX 070 145	Dimension of Linking Part 126~145 mm	Galv. steel	70
TTZX 070 165	Dimension of Linking Part 146~165 mm	Galv. steel	70
TTZX 070 200	Dimension of Linking Part 166~200 mm	Galv. steel	70
TTZJ 098 100	Dimension of Linking Parts≤80mm	Galv. steel	98
TTZJ 098 125	Dimension of Linking Part 101~125mm	Galv. steel	98
TTZJ 098 145	Dimension of Linking Part 126~145mm	Galv. steel	98
TTZJ 098 165	Dimension of Linking Part 146~165 mm	Galv. steel	98
TTZJ 098 200	Dimension of Linking Part 166~200 mm	Galv. steel	98
TTJG 030 075	Dimension of Linking Part 56~75 mm	Galv. steel	30
TTJG 030 075	Dimension of Linking Part 80~100 mm	Galv. steel	30
TTJG 030 075	Dimension of Linking Part 80~100 mm	Galv. steel	30

# Helical Fittings and Accessories for OPPC

## Dead-end set for OPPC

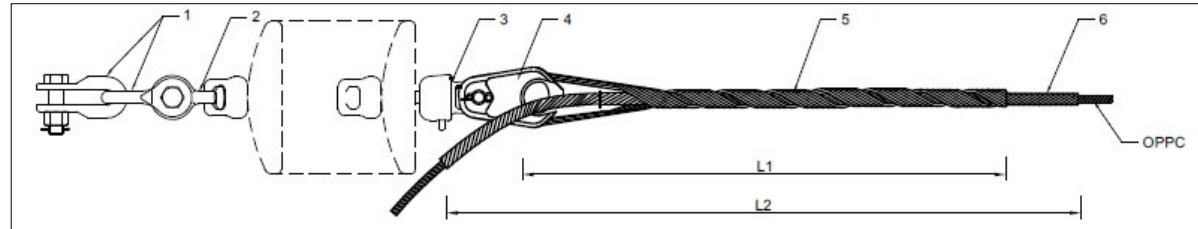

- 1. U Shackle: Galvanized Steel
- 2. Ball Eye: Galvanized Steel
- 3. Socket Tongue: Galvanized Steel
- 4. Thimble Clevis: Galvanized Steel
- 5. Dead-End Component: Aluminum-Clad Steel
- 6. Structural Reinforcing Rods: Aluminum-Clad Steel

### Product Characteristic

- The helical formed wire inner and outer layer components are designed to transfer axial tensile loads and distribute radial compressive forces over the surface in contact with the OPPC to minimize effects on the central core and internal optical fibers.
- The inside of inner and outer rods covered with silicon carbide, increasing damping effects.
- Minimum holding strength of dead-end set not less than 95% RTS of cable.
- Excellent anti-fatigue characteristic.
- The installation is convenient, no special tools needed.

### Consideration

- Once installed, structural reinforcing rods and dead-end component may be removed and reinstalled once for repositioning purpose. Do not reuse after this initial installation. The hardware components may be reused as long as they are in good condition. Do not modify any components.
- Right-hand lay is standard. Left-hand lay is available.
- Contact us in advance for the requirement of left-hand lay dead-end clamp.
- U shackle, Ball eye and other hardware accessories may be ordered with the dead-end. The fittings can only be installed by experienced workers.

### Catalogue Table of Dead-end for OPPC

Catalogue Number	Dia. Range		95% RTS (kN)	Structural reinforcing rods				Dead-end component			
	Min mm	Max mm		Length L2 (mm)	Diameter (mm)	No. of rods	Weight (kg)	Length L2 (mm)	Diameter (mm)	No. of rods	Weight (kg)
ONL-070-****	8	8.9	≤70	1400	2.5	11	0.54	1060	3.5	6	0.89
ONL-070-****	9	9.4	≤70	1400	2.5	12	0.59	1060	3.5	6	0.89
ONL-080-****	9.5	10.4	≤80	1500	2.5	13	0.68	1160	3.5	6	0.97
ONL-080-****	10.5	11.1	≤80	1500	2.5	14	0.74	1160	3.5	6	0.97
ONL-080-****	11.2	11.5	≤80	1500	2.5	14	0.74	1160	3.5	7	1.16
ONL-080-****	11.6	12.4	≤80	1500	2.5	15	0.79	1170	3.5	7	1.17
ONL-100-****			81-100	1600	2.5	15	0.84	1270	4.0	6	1.38
ONL-130-****			101-130	1900	2.5	15	1.00	1570	4.0	6	2.09
ONL-080-****	12.5	13.4	≤80	1600	2.5	16	0.90	1270	3.5	7	1.27
ONL-100-****			81-100	1700	2.5	16	0.95	1370	4.0	7	1.79
ONL-130-****			101-130	2000	2.5	16	1.12	1670	4.8	6	2.61

ONL-080-****	13.5	14.9	≤80	1600	2.5	17	0.95	1270	3.5	7	1.27
ONL-100-****			81-100	1800	2.5	17	1.07	1470	4.0	7	1.89
ONL-130-****			101-130	2000	2.5	17	1.19	1680	4.8	6	2.63
ONL-150-****			130-150	2100	2.5	17	1.25	1780	4.8	6	2.93
ONL-080-****	15.0	15.9	≤80	1600	2.5	17	0.95	1280	3.5	7	1.28
ONL-100-****			81-100	1800	2.5	17	1.07	1480	4.0	7	1.90
ONL-130-****			101-130	2000	2.5	17	1.19	1680	4.8	7	3.15
ONL-150-****			131-150	2100	2.5	17	1.25	1780	4.8	7	3.35
ONL-080-****	16.0	16.9	≤80	1700	2.5	18	1.07	1380	3.5	7	1.38
ONL-100-****			81-100	1900	2.5	18	1.20	1580	4.0	7	2.00
ONL-130-****			101-130	2100	2.5	18	1.32	1780	4.8	7	3.25
ONL-150-****			131-150	2200	2.5	18	1.32	1880	4.8	7	3.55
ONL-080-****	17.0	17.9	≤80	1700	2.5	19	1.13	1380	3.5	7	1.4
ONL-100-****			81-100	1900	2.5	19	1.26	1580	4.0	7	2.0
ONL-130-****			101-130	2100	2.5	19	1.40	1790	4.8	7	3.3
ONL-150-****			131-150	2200	2.5	19	1.46	1880	4.8	7	3.4
ONL-080-****	18.0	18.9	≤80	1800	3.0	18	1.46	1490	4.0	7	1.9
ONL-100-****			81-100	2000	3.0	18	1.70	1690	4.0	7	2.1
ONL-130-****			101-130	2200	3.0	18	1.78	1890	4.8	7	3.5
ONL-150-****			131-150	2300	3.0	18	1.86	1990	4.8	7	3.7
ONL-180-****			151-210	2500	3.0	18	2.03	2190	5.2	7	4.9
ONL-080-****	19.0	19.9	≤80	1800	3.0	19	1.54	1490	4.0	7	1.9
ONL-100-****			81-100	2000	3.0	19	1.71	1690	4.0	7	2.1
ONL-130-****			101-130	2200	3.0	19	1.88	1890	4.8	7	3.5
ONL-150-****			131-150	2400	3.0	19	2.10	2090	4.8	7	3.8
ONL-180-****			151-210	2600	3.0	19	2.31	2290	5.2	7	5.1
ONL-080-****	20.0	21.0	≤80	1900	3.0	20	1.71	1600	4.0	7	2.0
ONL-100-****			81-100	2100	3.0	20	1.89	1800	4.0	7	2.2
ONL-130-****			101-130	2300	3.0	20	2.07	2000	4.8	7	3.7
ONL-150-****			131-150	2500	3.0	20	2.25	2200	4.8	7	4.0
ONL-180-****			151-210	2700	3.0	20	2.43	2400	5.2	7	5.4

Note: \*\*\*\* is on behalf of diameter of OPPC;

## Catalogue Table of Dead-end for large strength OPPC

Catalogue Number	Suitable Strength(kN)	Inner rods (mm)		Middle rods (mm)		Outer rods (mm)	
		Dia.	Length	Dia.	Length	Dia.	Length
ONL-AAA-****	201~250	3.0	2200	4.0	1800	4.0	1500
ONL-AAA-****	251~350	3.0	2500	4.8	2200	4.8	2000
ONL-AAA-****	351~500	3.0	3000	5.2	2500	5.2	2200

Note: AAA- is 95% RTS of OPPC.

\*\*\*\*- is on behalf of OPPC diameter, e.g. 1350 indicates the diameter of OPPC is 13.50mm Dia.

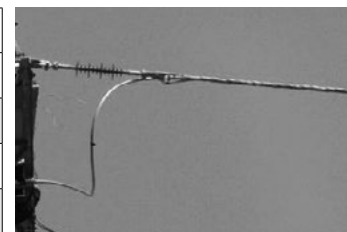



## ■ Suspension Set for OPPC

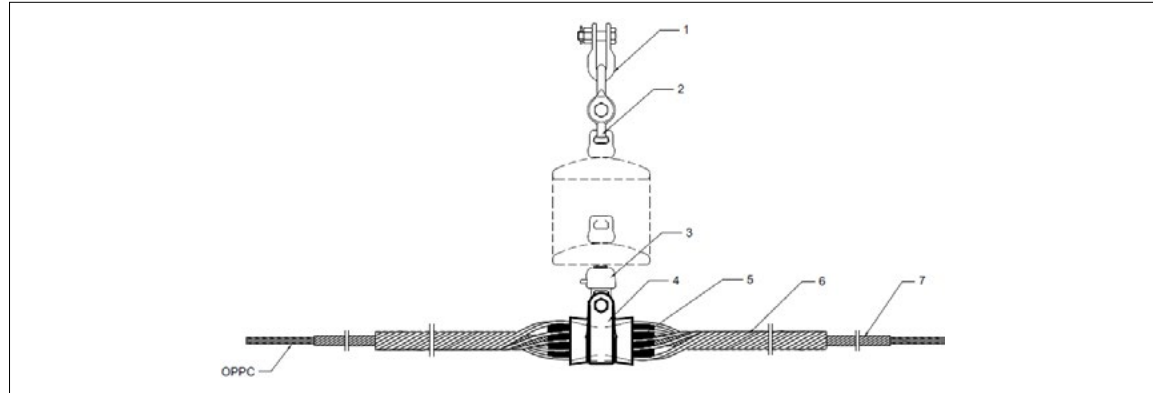

- |   |  |
|---|--|
| 1. U Shackle: Galvanized Steel                            | 5. Insert: EPDM                                |
| 2. Ball Eye: Galvanized Steel                             | 6. Outer Rods: Aluminum Alloy                  |
| 3. Socket Tongue: Galvanized Steel                        | 7. Structural Reinforcing Rods: Aluminum Alloy |
| 4. Cast Aluminum Clamp: Aluminum Alloy & Galvanized Steel |  |

### Product Characteristic

- The suspension set provides superior cable and fiber protection at the support point. The combination of Structural reinforcing rods, Outer rods, boltless cast aluminum clamp and resilient Insert reduces compression, clamping and bending stresses on cable. Negative weather-related cable motion, such as Aeolian vibration, galloping, and wind sway are also minimized.
- The insert for resistance to ozone attack, weathering, extreme high and low temperature variations. An aluminum alloy reinforcement is molded into the elastomer.
- The slip load of suspension set can reach approximate 10-20% of OPPC rated strength to offer sufficient holding strength for OPPC.

### Consideration

- The maximum recommended line angle for a single suspension set is 30°. Double one is recommended for OPGW line angle between 30° and 60°.
- Once installed, do not reuse the rod components. The hardware components may be reused as desired as long as they are in good condition. Do not modify any components.
- The fittings can only be installed by experienced workers.

### Catalogue Table of Single Suspension set for OPPC

Catalogue number	Span length (m)	Structural reinforcing rods (mm)		Outer rods		RTS Range (kN)
		Length L2	Diameter	Length L1	Diameter	
OCL-0200-****	≤200	1600	3.0	1000	6.0	≤40
OCL-0300-****	201-300	1800	3.0	1200	6.0	41-50
OCL-0400-****	301-400	1900	3.0	1300	6.0	51-60
OCL-0500-****	401-500	2000	3.0	1400	6.0	61-70
OCL-0600-****	501-600	2100	3.0	1500	6.0*	71-80
OCL-0700-****	601-700	2200	3.0	1600	6.0*	81-90
OCL-0800-****	701-800	2300	3.0	1700	6.0*	91-100
OCL-0900-****	801-900	2400	3.0	1800	6.0*	101-110
OCL-1000-****	901-1000	2500	3.0	1900	6.0*	111-120

Note: \*\*\*\* is on behalf of diameter of OPPC, e.g. 1350 indicates the diameter of OPPC is 13.50mm.

## Catalogue Table of Double Suspension clamp for OPPC

Catalogue Number	Cable Diameter Range (mm)	RTS Range (kN)	Distance L3 (mm)	Structural reinforcing rods		Outer rods	
				Length L2 (mm)	Diameter (mm)	Length L1 (mm)	Diameter (mm)
OSCL-****-400	9.0-15.0	≤100	400	2260	3.0	1660	6.0
		101-210	400	2660	3.0	2000	6.0
OSCL-****-400	15.1-16.4	≤100	400	2360	3.0	1760	6.0
		101-210	400	2760	3.0	2100	6.0
OSCL-****-400	16.5-16.9	≤100	400	2460	3.0	1860	6.0
		101-210	400	2860	3.0	2260	6.0
OSCL-****-450	17.0-19	≤120	450	2560	3.0	1960	6.3
		121-210	450	2960	3.0	2360	6.3
OSCL-****-660	> 19	≤120	660	2660	3.0	2060	7.9
		121-210	660	3060	3.0	2460	7.9

Note: \*\*\*\* on behalf of diameter of OPPC;

## ■ Cable Tray for OPPC

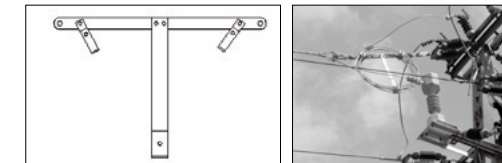

Sketch

Installation diagram

## ■ Joint Box for OPPC

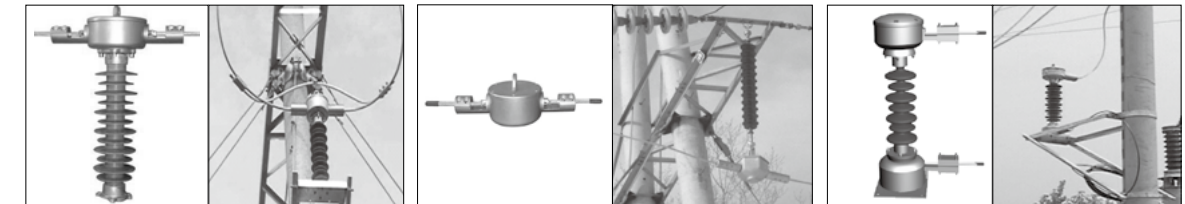

Jointing Support Joint Box

Jointing Suspension Joint Box

Terminal Joint Box

### Product Characteristic

- The joint box body is made of aluminum alloy, has good electric property
- The insulator part is made of silicone rubber
- Repeated used, easy to re-joint and expand capacity
- Installed on tower or pole alternative
- Good mechanical, sealing and anti-corrosion performance
- Has the function of transmission of not only optical communication but also electric power

### Technical specifications

- Fiber bending additional attenuation: ≤0.01dB
- Fiber bending radius: ≥30mm
- Retaining fiber length: ≥1.6m
- Tensile crush resistance: 2000N/100mm
- Environment temperature: -40°C ~+90°C
- Suitable voltage: 10-35kV, 66-110kV, 220kV
- Maximum fibers splice capacity: 144D

### Consideration

- The joint box can only be installed by experienced workers.
- Please consult ZTT for more information for installation method.

## ■ Vibration Damper

The OPPC's vibration dampers are similar as OPGW's.

# Helical Fittings and Accessories for Conductor

## Dead-end Clamp

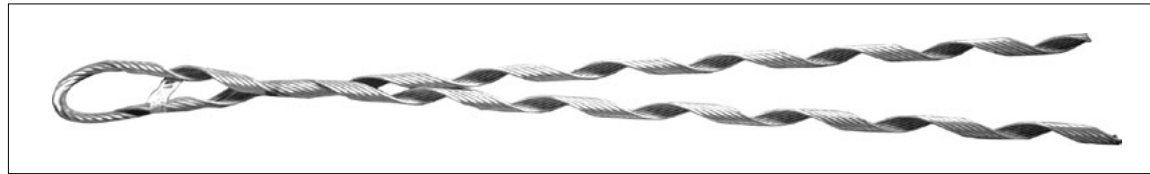

### Product Characteristic

- The materials of dead-end clamp differ for the matched conductors, generally, high-tensile aluminum alloy for aluminum alloy conductors; aluminum-clad steel for ACSR. Performed Dead-end clamps are used to fix conductors in the end or the middle of the overhead transmission lines. By wrapping the helical rods on a conductor, spring tension is created and the friction is produced between the conductor and rods. This friction ensures a constant gripping.
- Minimum holding strength of dead-end set not less than 95% RTS of cable.
- Excellent anti-fatigue characteristic.
- The installation is convenient, no special tools needed.

### Consideration

- Once installed, do not reuse after this initial installation. The hardware components may be reused as long as they are in good condition. Do not modify any components.
- Right-hand lay is standard. Left-hand lay is available.
- Contact us in advance for the requirement of left-hand lay dead-end clamp.
- The fittings can only be installed by experienced workers.

### Catalogue Table of Dead-end for Insulated conductor (1kV, 10kV)

Catalogue Number	Suitable conductor		Length (mm)	OD (mm)	Qty. of rod	Mass (kg)
	Section (mm <sup>2</sup> )	OD (mm)				
NL-35/JY	35	14.80	899	4.00	4	0.80
NL-50/JY	50	16.10	987	4.00	5	1.10
NL-70/LY	70	17.80				
NL-95/LY	95	19.60	1016	4.80	5	1.50
NL-120/LY	120	21.00				
NL-150/LY	150	22.60	1016	4.80	6	1.80
NL-185/LY	185	24.20				
NL-240/LY	240	26.40	1016	5.20	6	2.20
NL-300/LY	300	28.60				

### Installation Diagram

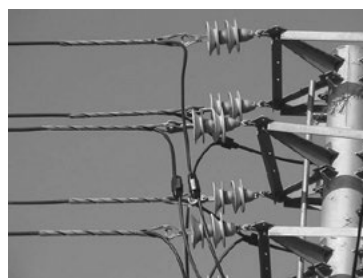

Dead-end for insulated conductor

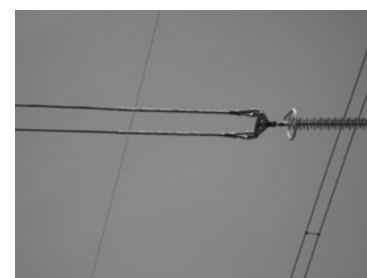

Dead-end for ACSR conductor



Dead-end for AAC conductor

### Catalogue Table of Dead-end clamp for ACSR

Catalogue Number	Suitable Conductor		Length (mm)	OD (mm)	Qty. of rod	Mass (kg)
	Section Al/St. (mm <sup>2</sup> )	OD (mm)				
NL-16/3	16/3	5.55	444	2.50	3	0.10
NL-25/4	25/4	6.96	546	2.50	3	0.10
NL-35/6	35/6	8.16	622	2.50	3	0.20
NL-50/8	50/8	9.60	685	3.00	3	0.20
NL-70/10	70/10	11.40	736	3.50	3	0.30
NL-50/30	50/30	11.60				
NL-70/40	70/40	13.60	876	3.50	4	0.60
NL-95/15	95/15	13.61				
NL-95/20	95/20	13.87				
NL-120/7	120/7	14.50	889	4.00	4	0.80
NL-120/20	120/20	15.07				
NL-95/55	120/25	15.74				
NL-120/25	120/25	15.74	1016	4.00	5	1.10
NL-150/8	150/8	16.00				
NL-150/20	150/20	16.67				
NL-150/25	150/25	17.10	1155	4.80	5	1.70
NL-150/35	150/35	17.50				
NL-120/70	120/70	18.00				
NL-185/10	185/10	18.00	1270	4.80	6	2.30
NL-185/25	185/25	18.90				
NL-185/30	185/30	18.88				
NL-210/10	210/10	19.00	1422	5.20	6	3.00
NL-180/45	180/45	19.60				
NL-210/25	210/25	19.98				
NL-210/35	210/35	20.38	1651	6.10	6	4.90
NL-210/50	210/50	20.86				
NL-240/30	240/30	21.60				
NL-240/40	240/40	21.66	1270	4.80	6	2.30
NL-240/55	240/55	22.40				
NL-300/15	300/15	23.01				
NL-300/20	300/20	23.43	1422	5.20	6	3.00
NL-300/25	300/25	23.76				
NL-300/40	300/40	23.94				
NL-300/50	300/50	24.26	1651	6.10	6	4.90
NL-300/70	300/70	25.20				
NL-400/20	400/20	26.91				
NL-400/25	400/25	26.64	1270	4.80	6	2.30
NL-400/35	400/35	26.82				
NL-400/50	400/50	27.63				
NL-400/65	400/65	28.00	1422	5.20	6	3.00
NL-400/95	400/95	29.14				
NL-500/35	500/35	30.00				
NL-500/45	500/45	30.00	1651	6.10	6	4.90

## Preformed Armor-grip Suspension Clamp

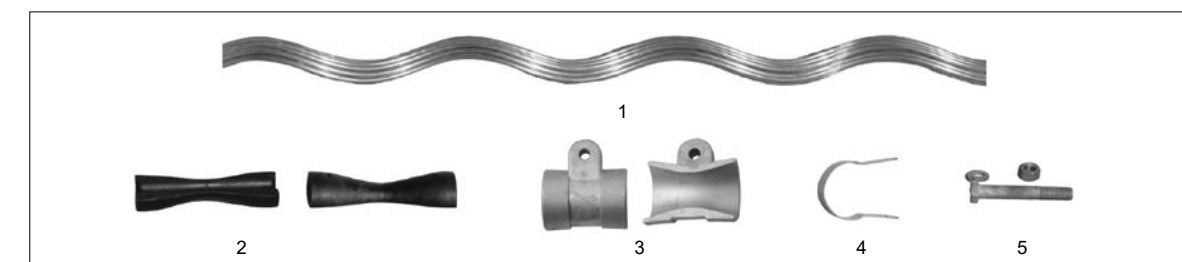

1. Armor rods: Aluminum alloy or Aluminum-clad steel
2. Insert: EPDM
3. Clamp body : Aluminum alloy

4. Belt: Aluminum alloy or Stainless steel
5. Bolts, nuts and washers: Galvanized steel



### Product Characteristic

- The suspension set provides superior cable and fiber protection at the support point. The combination of Structural reinforcing rods, Outer rods, boltless housing and resilient Insert reduces compression, clamping and bending stresses on cable. Negative weather-related cable motion, such as Aeolian vibration, galloping, and wind sway are also minimized.
- The insert for resistance to ozone attack, weathering, extreme high and low temperature variations. An aluminum alloy reinforcement is molded into the elastomer.
- The slip load of suspension set can reach approximate 14-20% of conductor rated strength to offer sufficient holding strength for conductor.
- The ends of armor rods are duckbill type to avoid corona.

### Consideration

- The maximum recommended line angle for a single suspension set is 30°. Double one is recommended for conductor line angle between 30° and 60°.
- Once installed, do not reuse the rod components.

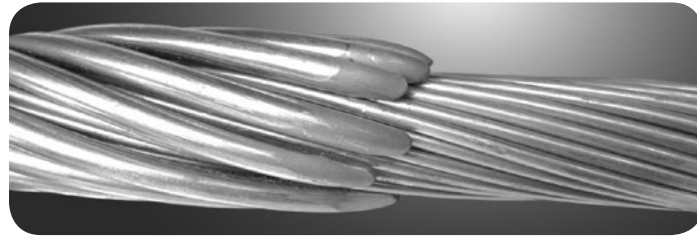

Duckbill type

### Catalogue Table of suspension clamp for AAC

Catalogue Number	Suitable conductor		Length (mm)	Diameter of rods (mm)	Qty. of rods	Mass (kg)
	Section (mm <sup>2</sup> )	OD (mm)				
CL-95	95	12.48	1016	4.20	10	1.10
CL-120	120	14.25	1118	4.60	11	1.40
CL-150	150	15.75	1270	4.60	12	1.50
CL-185	185	17.50	1372	5.20	11	1.80
CL-210	210	18.75	1422	5.20	12	2.00
CL-240	240	20.00	1524	6.40	11	2.60
CL-300	300	22.40	1651	6.40	12	3.10
CL-400	400	25.90	2032	7.90	11	5.50
CL-500	500	29.12	2083	7.90	12	5.90
CL-630	630	32.67	2235	9.30	12	8.80
CL-800	800	36.90	2235	9.30	13	9.70

### Catalogue Table of suspension clamp for ACSR

Catalogue Number	Suitable conductor		Length (mm)	Diameter of rods (mm)	Qty. of rods	Mass (kg)
	Section Al/St (mm <sup>2</sup> )	OD (mm)				
CL-35/6	35/6	8.16	660	2.60	11	1.10
CL-50/8	50/8	9.60	660	2.60	12	1.10
CL-70/10	70/10	11.40	914	3.30	11	1.50
CL-50/30	50/30	11.60	914	3.30	11	1.50
CL-70/40	70/40	13.60	1041	4.20	11	1.20
CL-95/15	95/15	13.61				
CL-95/20	95/20	13.87	1118	4.60	10	1.30
CL-120/7	120/7	14.50	1118	4.60	11	1.40
CL-120/20	120/20	15.07	1143	4.60	11	1.40
CL-120/25	120/25	15.74	1143	4.60	11	1.40
CL-95/55	95/55	16.00	1270	4.60	12	1.50
CL-150/8	150/8	16.00				
CL-150/20	150/20	16.67	1372	5.20	11	1.80
CL-150/25	150/25	17.10				
CL-150/35	150/35	17.50	1372	5.20	11	1.80
CL-120/70	120/70	18.00	1372	5.20	12	1.90
CL-185/10	185/10	18.00				
CL-185/25	185/25	18.90	1422	5.20	12	2.00
CL-180/30	180/30	18.88				
CL-210/10	210/10	19.00	1524	6.40	11	2.60
CL-180/45	180/45	19.60				
CL-210/25	210/25	19.98	1549	6.40	11	2.80
CL-210/35	210/35	20.38				
CL-210/50	210/50	20.86	1626	6.40	11	2.90
CL-240/30	240/30	21.60				
CL-240/40	240/40	21.66	1651	6.40	12	3.10
CL-240/55	240/55	22.40				
CL-300/15	300/15	23.01	1676	6.40	12	4.10
CL-300/20	300/20	23.43				
CL-300/25	300/25	23.76	1702	6.40	12	4.10
CL-300/40	300/40	23.94				
CL-300/50	300/50	24.26	1753	6.40	13	4.40
CL-300/70	300/70	25.20				
CL-400/20	400/20	26.91	2083	7.90	11	5.70
CL-400/25	400/25	26.64				
CL-400/35	400/35	26.82	2083	7.90	12	5.90
CL-400/50	400/50	27.63				
CL-400/65	400/65	28.00	2083	7.90	12	5.90
CL-400/95	400/95	29.14				
CL-500/35	500/35	30.00	2083	7.90	12	6.00
CL-500/45	500/45	30.00				
CL-500/65	500/65	30.96	2235	9.30	11	8.30
CL-630/45	630/45	33.60	2235	9.30	12	8.80
CL-630/55	630/55	34.62	2235	9.30	12	9.10
CL-630/80	630/80	34.82				
CL-800/55	800/55	38.40	2235	9.30	13	9.70
CL-800/70	800/70	38.58	2235	9.30	13	9.70
CL-800/100	800/100	38.98				

### ■ Matching Fittings of Double Suspension Set

- Yoke plate

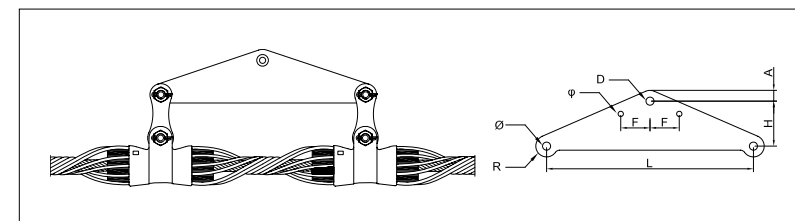

Type	Dimension (mm)								Mass (kg)
	L	H	D	R	A	F	Φ	φ	
L-0730	305	90	24	24	25	70	20	22	3
L-1045	450	100	26	24	32	100	20	22	5.2
L-1256	560	120	26	24	32	120	20	22	7.15
L-1666	660	150	28	30	33	140	24	22	11.55
L-1673	737	170	26	30	33	140	24	22	14.1
L-2161	610	190	26	30	34	140	24	22	16.6

● "Y" type plate (for vertical twin bundle)

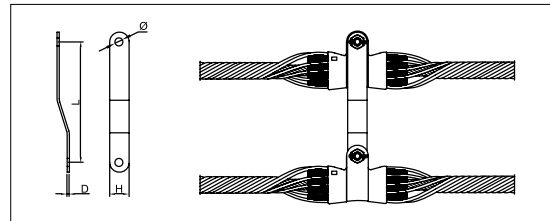

Type	Dimension (mm)				Mass (kg)
	L	H	Φ	D	
LB-25	305	45	18	8	3
LB-40	400	45	20	10	5.2
LB-50	500	45	24	12	
LB-60	600	45	26	16	

Installation Diagram



Single set for conductor



Single set for earth-wire



Double set

■ Armor Rods, Repair Rods and Helical Splices



Armor Rods

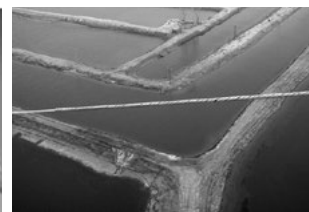

Repair Rods



Helical Splices

■ Armor Rods and Repair rods

Armor rods are used for protecting the cables from the damage caused by vibration, pressure of clamps, friction, electric arc etc. It consists of a set of preformed

rods, winding up the cables.

Repair rods are used for repairing the damaged cables, recovering the cables' strength and conductivity.

Products Characteristic

- Good manufacturing process to ensure the cables can be hold tightly.
- They are made of aluminum alloy or aluminum-clad steel, with excellent corrosion-resistant ability.
- With the smooth surface and duckbill type ends make them have good performance on anti-corona and anti-radio interference.
- Easily installed by bare hand, no special tools need.

Consideration

- Once installed, do not reuse the rod components.
- The fittings can only be installed by experienced workers.

Catalogue Table of Repair Rods

Catalogue Number	Suitable conductor		Diameter of rods (mm)	Length (mm)	Qty. of rods
	Type	OD(mm)			
BL-95/15	LGJ-95/15	13.61	3.60	420	13
BL-95/20	LGJ-95/20	13.87			13
BL-95/55	LGJ-95/55	16.00			16
BL-120/7	LGJ-120/7	14.50	3.60	450	14
BL-120/20	LGJ-120/20	15.07			
BL-120/25	LGJ-120/25	15.74			
BL-150/8	LGJ-150/8	16.00	3.60	480	16
BL-150/20	LGJ-150/20	16.67			
BL-150/25	LGJ-150/25	17.10			
BL-150/35	LGJ-150/35	17.50			

Catalogue Table of Armor Rods for AAC

Type	Section of AAC (mm <sup>2</sup> )	Dia. of AAC (mm)	Dia. of Rods (mm)	Length (mm)
FYH-63/LJ	63	10.9	3.0	1000
FYH-70/LJ	70	10.7	3.0	1000
FYH-95/LJ	95	12.5	3.6	1200
FYH-100/LJ	100	14.0	3.6	1200
FYH-120/LJ	120	14.2	3.6	1200
FYH-125/LJ	125	15.6	3.6	1200
FYH-150/LJ	150	15.9	3.6	1400
FYH-160/LJ	160	17.6	3.6	1400
FYH-200/LJ	200	19.7	3.6	1400
FYH-210/LJ	210	18.8	3.6	1400
FYH-240/LJ	240	20.1	4.6	1600
FYH-250/LJ	250	22.1	4.6	1600
FYH-300/LJ	300	22.5	6.3	1800
FYH-315/LJ	315	24.8	6.3	1800
FYH-400/LJ	400	26.0	6.3	2000
FYH-450/LJ	450	29.7	6.3	2000
FYH-500/LJ	500	29.1	7.9	2000
FYH-560/LJ	560	33.2	7.9	2000
FYH-630/LJ	630	32.7	7.9	2200
FYH-710/LJ	710	37.3	7.9	2200
FYH-800/LJ	800	36.8	9.3	2400
FYH-900/LJ	900	42.1	9.3	2400
FYH-1000/LJ	1000	41.1	9.3	2400
FYH-1120/LJ	1120	46.9	9.3	2400

Catalogue Table of Armor Rods for ACSR

Catalogue Number	Suitable conductor		Diameter of rods(mm)	Length (mm)	Qty. of rods
	Type	OD(mm)			
FYH-95/15	LGJ-95/15	13.61	3.60	1400	13
FYH-95/20	LGJ-95/20	13.87		1400	13
FYH-95/55	LGJ-95/55	16.00		1500	16
FYH-120/7	LGJ-120/7	14.50	3.60	1400	14
FYH-120/20	LGJ-120/20	15.07			
FYH-120/25	LGJ-120/25	15.74			
FYH-120/70	LGJ-120/70	18.00		1800	
FYH-150/8	LGJ-150/8	16.00	3.60	1500	16
FYH-150/20	LGJ-150/20	16.67			
FYH-150/25	LGJ-150/25	17.10			
FYH-150/35	LGJ-150/35	17.50			
FYH-185/10	LGJ-185/10	18.00			
FYH-185/25	LGJ-185/25	18.90			
FYH-185/30	LGJ-185/30	18.88	4.60	1800	14
FYH-185/45	LGJ-185/45	19.60			
FYH-210/10	LGL-210/10	19.00			
FYH-210/25	LGL-210/25	19.98			
FYH-210/35	LGL-210/35	20.38	4.60	1800	14
FYH-210/50	LGL-210/50	20.86			
FYH-240/30	LGL-240/30	21.60			
FYH-240/40	LGL-240/40	21.66			
FYH-240/55	LGL-240/55	22.40	4.60	1900	16
FYH-300/15	LGJ-300/15	23.01			
FYH-300/20	LGJ-300/20	23.43			
FYH-300/25	LGJ-300/25	23.76			
FYH-300/40	LGJ-300/40	23.94			
FYH-300/50	LGJ-300/50	24.26			
FYH-300/70	LGJ-300/70	25.20	6.30	2000	13
FYH-400/20	LGJ-400/20	26.91			
FYH-400/25	LGJ-400/25	26.64			
FYH-400/35	LGJ400/35	26.82			
FYH-400/50	LGJ400/50	27.63			
FYH-400/65	LGJ400/65	28.00			
FYH-400/95	LGJ400/95	29.14	6.30	2500	16
FYH-500/35	LGJ500/35	30.00			
FYH-500/45	LGJ500/45	30.00			
FYH-500/65	LGJ500/65	30.96			
FYH-630/45	LGJ630/45	33.60	7.80	2500	16
FYH-630/55	LGJ630/55	34.32			
FYH-630/80	LGJ630/80	34.82			
FYH-800/55	LGJ800/55	38.40	7.80	2500	17
FYH-800/70	LGJ800/70	38.58			
FYH-800/100	LGJ800/100	39.98			

### Helical Splices

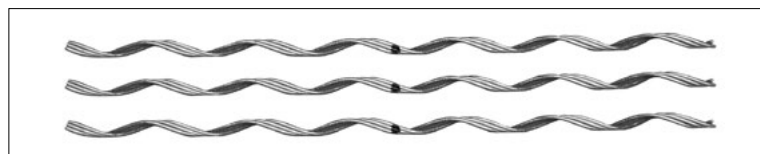

#### Product Characteristic

- Helical steel splices are manufactured by high strength galvanized steel wire. Steel splices may be used in all environments for which galvanized steel conductor or guy wire may be used. Steel splices are designed to hold the full rated strength and the full load current of galvanized steel conductors or guy wires.
- Helical aluminum splices are manufactured by high strength corrosion resistant aluminum alloy wire. Aluminum splices may be used in all environments. Aluminum splices are designed to hold the full rated strength and full load current of AAC or AAAC conductors.

#### Consideration

- Once installed, do not reuse the rod components.
- The Helical Splices can only be installed by experienced works
- Scratch brush the conductor to get rid of the oxide coating and grease the conductor before installation

Catalogue Table of Helical Splices for Galvanized steel wire

Catalogue Number	Suitable conductor		Length (mm)	Diameter of rods (mm)	Qty. rods	Mass (kg)
	Type	OD (mm)				
JL-25/G	GJ-25	6.60	910	2.20	10	0.30
JL-35/G	GJ-35	7.80	1070	2.50	10	0.40
JL-50/G	GJ-50	9.00	1220	2.50	12	0.60
JL-70/G	GJ-70	11.00	1450	3.50	11	1.30

Catalogue Table of Helical Splices for AAC or AAAC

Catalogue Number	Suitable conductor		Length (mm)	Diameter of rods (mm)	Qty. rods	Mass (kg)
	Section (mm <sup>2</sup> )	OD (mm)				
JL-95/L	95	12.48	1168	3.70	11	0.40
JL-120/L	120	14.25	1321	4.20	11	0.60
JL-150/L	150	15.75	1702	4.60	12	1.10
JL-185/L	185	17.50	1778	5.20	11	1.20
JL-210/L	210	18.75	2007	6.40	10	1.90
JL-240/L	240	20.00	2108	6.40	11	2.20
JL-300/L	300	22.40	2515	6.40	12	2.80
JL-400/L	400	25.90	3073	7.90	11	4.80
JL-500/L	500	29.12	3581	9.30	11	7.80
JL-630/L	630	32.67	3784	9.30	12	8.90
JL-800/L	800	36.90	4394	11.10	11	13.60

Note: please consult ZTT for more information.

### Helical Full Tension Splices

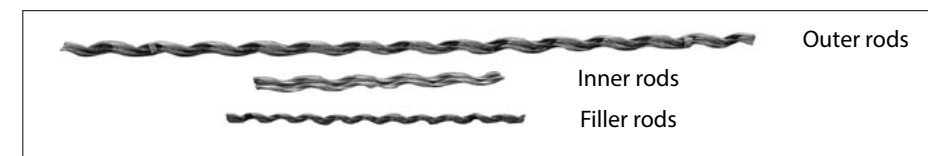

#### Product Characteristic

- The Full Tension Splices consist of outer rods, inner rods and filler rods, which manufactured by high strength corrosion resistant aluminum alloy wire and high strength. Full Tension Splices are designed to hold the full rated strength and carry the full load current of ACSR conductors.
- The Full Tension Splices are mainly used to joint the recover the broken or damaged ACSR conductor and may be used in all environments for which ACSR conductors are used.

#### Consideration

- Once installed, do not reuse the rod components.
- The Helical Splices can only be installed by experienced works
- Scratch brush the conductor to get rid of the oxide coating and grease the conductor before installation



Catalogue Table of Helical Splices for ACSR

Catalogue Number	Suitable conductor	Length Inner/Filler/Outer rods (mm)	Diameter of rods (mm)	Qty. rods	Mass Inner/Filler/Outer rods (kg)
JL-50/8	LGJ-50/8	508/Null/1372	3.00/ Null/3.10	5/ Null /11	0.20/Null/0.30
JL-70/10	LGJ-70/10	406/406/1499	1.80/1.80/4.20	8/13/10	0.10/0.10/0.60
JL-95/15	LGJ-95/15	508/508/1905	2.20/2.20/4.20	8/14/11	0.10/0.10/0.90
JL-95/20	LGJ-95/20	508/508/1727	1.80/2.40/4.20	10/13/11	0.10/0.10/0.80
JL-95/0	LGJ-95/0	737/737/1880	1.80/2.40/4.20	10/13/11	0.10/0.10/0.80
JL-120/20	LGJ-120/20	508/508/2057	1.80/3.10/4.60	10/10/11	0.10/0.10/1.10
JL-120/0	LGJ-120	610/610/2210	2.20/2.40/2.60	10/14/11	0.20/0.10/1.20
JL-150/0	LGJ-150	635/635/2387	2.20/3.10/5.20	10/12/11	0.20/0.20/1.60
JL-150/20	LGJ-150/20	508/50//2261	1.80/3.70/5.20	10/9/11	0.10/0.10/1.50
JL-150/20	LGJ-150/20	635/635/2413	2.20/3.10/5.20	10/12/11	0.20/0.10/1.60
JL-150/35	LGJ-150/35	686/686/2465	2.50/2.40/5.20	10/17/11	0.30/0.10/1.60
JL-185/30	LGJ-185/30	660/660/2667	2.20/3.70/6.40	11/11/10	0.20/0.20/2.40
JL-185/25	LGJ-185/25	635/635/2642	2.20/4.20/6.40	10/9/10	0.20/0.20/2.40
JL-185/0	LGJ-185	686/686/2692	2.50/3.10/6.40	10/13/10	0.30/0.20/2.50
JL-210/25	LGJ-210/25	635/635/2743	2.20/4.60/6.40	10/9/11	0.20/0.30/2.80
JL-240/0	LGJ-240	787/787/3226	3.00/3.50/7.90	10/14/10	0.50/0.30/4.50
JL-240/30	LGJ-240/30	686/686/3073	2.50/4.60/7.00	10/10/11	0.30/0.30/3.70
JL-240/40	LGJ-240/40	737/737/3073	2.50/4.20/6.40	11/11/12	0.30/0.30/3.40
JL-240/0	LGJQ-240	658/658/3124	2.50/4.60/7.00	10/10/11	0.30/0.30/0.38
JL-300/(1)	LGJQ-300(1)	711/711/3404	2.50/5.20/7.90	10/9/11	0.30/0.40/5.20
JL-300/25	LGJ-300/25	635/635/3759	2.20/6.40/7.90	10/7/11	0.20/0.40/5.80
JL-300/40	LGJ-300/40	737/737/3429	2.50/5.20/7.90	11/9/11	0.30/0.40/5.30
JL-300/0	LGJ-300	1041/1041/3657	3.00/4.60/7.90	11/12/11	0.70/0.60/5.70
JL-400/25	LGJ-400/25	635/635/4013	2.20/7.90/9.30	10/6/10	0.20/0.50/7.90
JL-400/35	LGJ-400/35	686/686/4242	2.50/7.00/9.30	10/7/10	0.30/0.50/8.00
JL-400/50	LGJ-400/50	787/787/4343	2.50/6.40/9.30	12/8/10	0.40/0.60/8.20
JL-400/0	LGJ-400	1168/1168/4216	3.00/5.20/9.30	12/11/10	0.80/0.80/8.20
JL-500/45	LGJ-500/45	787/787/4445	3.00/7.90/11.10	10/7/9	0.50/0.80/11.20
JL-500/35	LGJ-500/35	686/686/4445	2.50/8.50/11.10	10/6/9	0.30/0.70/11.20
JL-500/65	LGJ-500/65	889/889/4724	3.00/7.00/11.10	11/9/10	0.60/0.90/13.20

Note: please consult ZTT for more information.

## ■ Preformed Vibration Damper Series

Preformed Vibration Damper is used on conductor, ground wire and optical fiber cable. ZTT designs different vibration damper products according to different conductor type. Preformed Vibration Damper owns many structures, and Hook type Preformed vibration

Damper is specified designed for common conductor, thermal-resistant conductor, ACS Conductor. Rubber type Preformed vibration damper is specified designed for Annealed Aluminum Conductor, ACCC, and ACCR.

### Product Characteristic

- On the basis of adoption of the method of combination of theoretical calculation and experimental—using vibration table, furthermore we design and optimize. The property of products is excellent. The frequency of vibration damper reaches 80Hz, energy consumption reaches 3W and protection length reaches 594m.
- Preformed armor rod imposes strong grip strength on the wire to prevent clamp loose and product slipping caused by long-term vibration fatigue which would put damage to the vibration-proof scheme of the wire.
- The preformed armor rod stress distributes evenly alongside the wire thus deducts the collective stress the traditional screw-type vibration damper clamp puts on the wire.
- Messenger cable, which is made by our factory, has a high elastic modulus and tensile strength which guarantees each properties of the vibration damper.
- The clamp and messenger cable adopts surface com-

- pression manner to secure the force uniform, while the traditional method is direct casting, but the high temperature affects the properties of the messenger cable, furthermore the point-pressure method cannot meet the requirement of grip strength. Weights and messenger cable adopts the riveting process to secure that the weights would never drop.
- The preformed vibration damper carries on a lot of advantages of preformed helical fitting. Compared to the traditional vibration damper, it could be easily installed by bare hand without special tool.
- The end of the preformed armor rods adopt the method of duckbill processing to avoid the electric corona and corrosion, the surface of the vibration damper adopts the latest corrosion-proof method to avoid the corrosion, breakage of the messenger cable and rusting of the weights alike problems which would influence the product quality.

### Consideration

- Once installed, do not reuse the rod components.
- The Helical Splices can only be installed by experienced works.
- Scratch brush the conductor to get rid of the oxide coating and grease the conductor before installation.

## ■ Rubber type preformed vibration damper

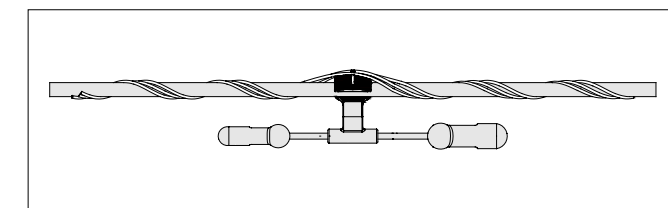
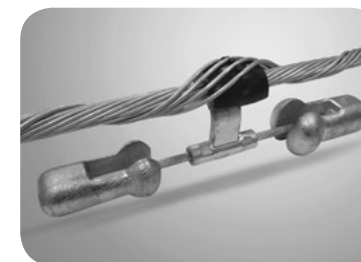

The ordinary vibration damper is rigid contact. After long used in the line, the outer lay of the conductor easily fatigue causing the strands broken. The rubber of rubber type vibration damper is tightly wrapped around the clamp and would never drop. This kind of rubber possesses excellent properties of high temperature-resistance, aging-resistance, ultraviolet rays-resisting to

effectively protect the surface of the conductor from wearing. The damping characteristic of the rubber can be used to protect the aluminum wire in the out layer of the wire, which makes that this kind of vibration damper could be used in the soft aluminum conductor and carbon fiber conductor and so on.

### Catalogue Table

Type	Suitable conductor range (mm)	Suitable section area	Weight (kg)
PVD4D10XJ	7.0-11.40	25mm <sup>2</sup> -70mm <sup>2</sup>	1.2
PVD4D20XJ	13.87-18.00	70mm <sup>2</sup> -185mm <sup>2</sup>	1.4
PVD4D30XJ	18.90-25.30	185mm <sup>2</sup> -300mm <sup>2</sup>	2.3
PVD4D40XJ	25.20-30.00	300mm <sup>2</sup> -500mm <sup>2</sup>	4.5
PVD4D50XJ	32.00-39.98	500mm <sup>2</sup> -800mm <sup>2</sup>	5.1

### ■ Hook type preformed vibration damper (Symmetrical) for conductor

Preformed armor rods are made of al-alloy and duckbill dealing on the tips; the surface of Weights is smooth and has excellent curvature, to prevent corona. The

armor rods go through the middle of the clamp to make the clamp on the conductor tightly. The weights are symmetrically designed.

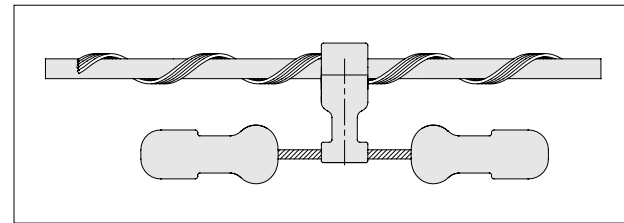
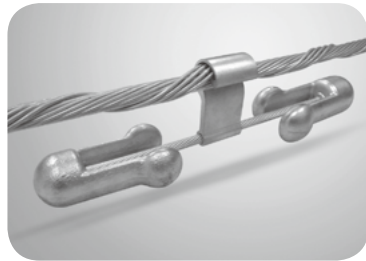

### Catalogue Table

Type	Suitable conductor diameter (mm)	Suitable conductor types	Weight (kg)
PVD2D-2	27-31	400/50 400/65 400/95 500/35 500/45 500/65	5.0
PVD2D-3	31-35	630/45 630/51 630/80	5.1
PVD2D-4	35-39	720/50 800/55 800/70 800/100	7.5
FDYJ-8	39-43	1000	8.5

Note: For section area of conductor below 400mm<sup>2</sup>, ZTT recommends to select asymmetrical dampers.

### ■ Hook type preformed vibration damper (asymmetrical) for conductor and ground wire

For the ground wire and small section area conductor with high frequency, the damper adopts asymmetrical

design to offer comprehensive frequency and high energy consumption.

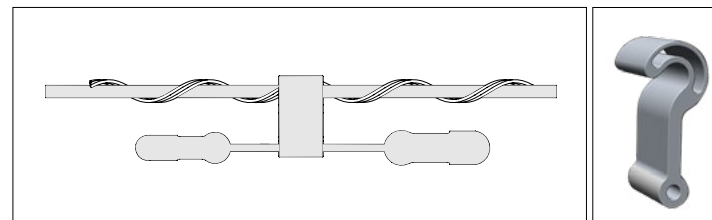
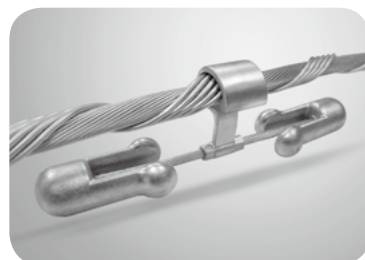

### Catalogue Table

Type	Suitable conductor diameter (mm)	Suitable conductors		Weight (kg)	Suitable for
		ACSR(GB1179)	ACS		
PVD4D20	7-13.5	25/4 35/6 35/6 50/8 50/30 70/10	16 25 40 63	1.5	Ground wire
PVD4D30	13.5-17.5	70/40 95/15 95/20 95/55 120/25 125/70	65 70 80 95 100 120 150	2.7	Ground wire
PVD4D35	17-23	185/30 210/35 210/50 240/30 240/40 240/55	180 185 210 240	3.8	Ground wire and conductor
PVD4D40	23-27	300/15 00/20 300/25 300/40 300/50 300/70 400/20 400/25 400/35	\	4.5	Conductor

### ■ Armor-grip Spacer Damper

Spacers are installed on multi-bundle conductors to keep certain distance among each conductor so as to avoid impact and restrain wind vibration and sub-span oscillation. Traditional spacers are difficult to install, causing low working efficiency; traditional spacers slip

easily on conductors, leading to asymmetrical stress distribution on conductors. Armor-grip spacer dampers are easily installed and simply operated, with preformed armor rods which provide large contact-area to prove balanced adhesive power.

#### Product Characteristic

- Preformed armor rod imposes strong grip strength on the wire to Armor-grip armor rods, which are easily installed, energy-saving and environmental-friendly, enlarge the gripping strength on conductor. All-alloy material, with no eddy current loss, reduces the loss during line operation. Duckbill handling to the end of the rods prevents the interference of corona and radio.
- Rubber makes the soft-contact between spacer and conductor, reducing the worn of conductor to a great extent. Rubber, with the following characters, such as

- environmental-friendly, hard-wearing, high-temperature resistance, semi conductive, is fully qualified the requirements of high-voltage and ultra-high-voltage lines. Using advanced technology makes the elastomer coat closely to the spacer.
- Anti-fatigue, maintenance free, no bolt looseness problems. Preformed armor rods actively make reparation of looseness caused by creep, plastic deformation and vibration of conductor, increasing the anti-fatigue character of conductor and spacer.



8 rubber columns in the clamp damper part



Outer layer with rubber and al-alloy framework guarantee the strength



Clamp tip with rubber to protect conductor

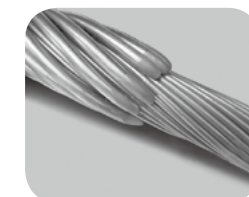

Preformed armor rods tip with anti-corona duckbill handling

# Reference

## ■ Armor-grip Twin Spacer Damper

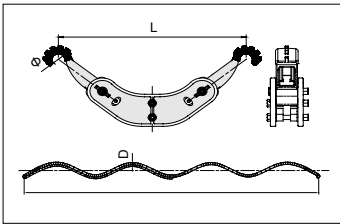

Catalogue No.	Suitable range (mm)	Suitable conductor	Main dimensions (mm)		
			L	Φ	D
FJZ-240/24DY	18.0-22.0	LGJ-185/10 ~ 45 LGJ-210/25 ~ 50 LGJ-240/30 ~ 40	400	22.0	4.6
FJZ-240/30DY	22.0-26.0	LGJ-240/55 LGJ-300/15 ~ 70	400	26.0	4.6
FJZ-240/40DY	26.0-30.0	LGJ-400/20 ~ 95	400	30.0	4.6
FJZ-240/63DY	30.0-34.0	LGJ-500/35 ~ 65	500	34.0	6.0

## ■ Armor-grip Quad Spacer Damper

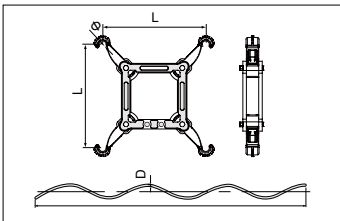

Catalogue No.	Suitable range (mm)	Suitable conductor type	Main dimensions (mm)		
			L	Φ	D
FJZ-445F/300Y	21.0-25.0	LGJ-300/25 ~ 50	450	25.0	4.6
FJZ-445F/400Y	26.0-29.0	LGJ-400/25 ~ 65	450	29.0	4.6
FJZ-445F/500Y	29.0-31.0	LGJ-500/35 ~ 65	450	31.0	6.0
FJZ-445F/630Y	31.0-35.0	LGJ-630/45 ~ 81	450	35.0	6.0
FJZ-450F/500Y	29.0-31.0	LGJ-500/35 ~ 65	500	31.0	6.0
FJZ-450F/630Y	31.0-34.0	LGJ-630/45 ~ 80	500	34.0	6.0
FJZ-450F/720Y	34.0-37.0	LGJ-720/50	500	37.0	6.0
FJZ-450F/1000Y	39.0-43.0	LGJ-900/40 ~ 75 LGJ-1000/45	500	43.0	6.4

## ■ Armor-grip Quad Spacer Damper

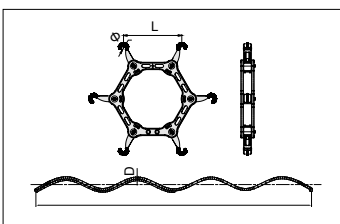

Catalogue No.	Suitable range (mm)	Suitable conductor type	Main dimensions (mm)		
			L	Φ	D
FJZ-640/400Y	24.0-28.0	LGJ-400/35 LGJ-400/50	400	28.0	4.6
FJZ-640/500Y	28.0-31.0	LGJ-500/35 LGJ-500/50	400	31.0	6.0
FJZ-645/720Y	33.0-37.0	LGJ-630/45 LGJ-630/55 LGJ-720/50	450	37.0	6.0
FJZ-645/900Y	39.0-43.0	LGJ-900/40 ~ 75 LGJ-1000/45	450	43.0	6.4

ZTT has accrued more than 300,000km successful operation performance. We have achieved many years of running performances on 110kV, 220kV, 500kV transmission lines. Celebrating our products, having been successfully applied in Top Projects in China; such as

the 1000kV UHV AC, 800kV UHV DC, and several 750kV transmission line projects. Complete fitting products of our company have been exported to more than 100 countries, from Asia to Africa, Europe, South America, Oceania and North America.

## ■ Typical project

### Xiangjiaba-Shanghai ±800kV UHV DC Transmission Line (in China)

#### Project information:

- Voltage: DC ±800KV
- Length: 1907 km
- No. of Towers: 3939
- Finished time: July 2010

#### Supply products:

- Conductor: ACSR-720/5012, 000 tons
- OPGW: Dia.17.5mm RTS: 202KN  
Dia.24.7mm RTS: 527KN  
Total length: 550km
- Fittings for OPGW and ACSR

### Qinghai Golmud to Tibet Lhasa ±400kV DC networking project (in China)

#### Project information:

- Voltage: DC ±400KV
- Length: 1308 km
- Ultra-low temperature: -60°C
- The highest altitude: 5300m

- Finished time: Dec. 2011

#### Supply products:

- ACSR conductor 2630km
- OPGW for this project, total 625km
- Fittings for OPGW

### 110kV Guangdong Xiachuandao-Huangjingzhou Over-the-Sea large span project (in China)

#### Project information:

- The max span: 1949m
- Tower height: 285m
- OPGW RTS: 463.3kN

- Operation Date: July 2010

#### Supply products:

- OPGW, fittings for OPGW with damper scheme

### 400 KV D/C River Crossing (Haldia-Subhasgram) (in India)

#### Project information:

- The max span: 1572m
- OPGW RTS: 441.2kN
- OPGW Dia: 25.98kN

#### Ordered products:

- OPGW
- Fittings for OPGW with damper schedule

### 132kV Meghna River Crossing at Tetia-Kanainagar (ICB:PGCB/132kV/TL. T-LRC) (in Bangladesh)

#### Project information:

- The max span: 1600m
- OPGW RTS: 239.3kN
- OPGW Dia: 18.3kN

#### Ordered products:

- OPGW
- Fittings for OPGW with damper schedule

### 220KV Chaglla Transmission Line (in Peru)

#### Project information:

- The max span: 1967.48m
- The max altitude: 4454.71mm

#### Ordered products:

- OPGW, conductor
- Fittings for OPGW and conductor

**Delivery date: May, 2014**